

ENGINEERING MANUAL

FDA Approved Materials
& Components

Fast, Simple to Use
Online Configurator

Rapid Deliveries

BISSC
Certified Conveyors



*Aqua***Gard**[®]

7350 SERIES CONVEYORS

Stainless Steel Conveyors for Dry,
Wipe Down and Wet Applications

DORNER[®]

By Columbus McKinnon

Sleek, Low Profile Design - 7200 & 7300 Series*

- Quick, five-minute belt change for increased uptime
- Rack and pinion for fast, single point belt tensioning
- V-Groove frame with V-Guided belt ensures accurate tracking
- Streamlined design fits where other conveyors do not
- Low profile, single piece frame for quick, easy cleaning
- Quick-clamp rail for easy mounting of bolt-on accessories

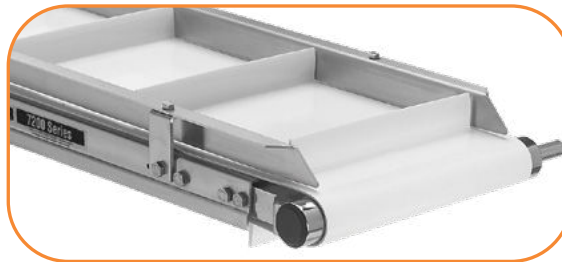

Rugged and Durable Design - 7350 Series

- 304 Stainless Steel frame features open design with minimal horizontal surfaces
- Designed for wipe down and low pressure wash-down with non-caustic chemicals
- V-guided belt tracking on belted models
- Tip-up tails for access inside the conveyor for cleaning and maintenance
- Safest chain in the industry with chain openings less than 4 mm even on curves
- Unique chain design virtually eliminates friction providing capacity for up to 4 curves on a single conveyor



Tip-Up Tails



Innovative Chain Design



Positive Drive Belt

Engineered Solutions

- Dorner's Engineered Solutions Group can tailor fit AquaGard Conveyors for specific applications and product handling requirements
- With a custom-designed conveyor system in place and the help of highly specialized engineering, your products are processed faster, your services are delivered quicker, and your profits are increased
- Solutions include: chicaning, retracting tails, depositing and rejects, merging, product flow, and more!



The Benefits of Dorner AquaGard Conveyors

Industry Ready

- Designed and manufactured to food equipment standards
- BISSC certified conveyors
- FDA approved materials and components
- Washdown rated gearmotors and controls

A Focus on Speed

- Dorner sets the industry standard for rapid delivery
- Sanitary conveyors ship in as little as 10 business days
- Fast and effective design reduces cleaning preparation time

*Please refer to the AquaGard 7200 & 7300 Series manual for product information.

FABRIC BELTS & POSITIVE DRIVE BELTS
PAGE 21-25

MODULAR BELT CONVEYORS PROFILES & GUIDING
PAGE 40-41

POSITIVE DRIVE CONVEYORS
PAGE 16-19

BELTED CONVEYORS PROFILES & GUIDING
PAGE 20

BELTED CONVEYORS
PAGE 4-15

MODULAR BELTS
PAGE 42-43

GEARMOTORS
PAGE 47-48

SUPPORT STANDS & ACCESSORIES
PAGE 50-53

MODULAR BELT CONVEYORS
PAGE 28-39

CONTROLS
PAGE 49

POWERED TRANSFER
PAGE 35

GEARMOTOR MOUNTING PACKAGES
PAGE 44-45

BELT SPEED CHARTS
PAGE 46

ACCESSORIES
PAGE 54-55



TECHNICAL DATA & CALCULATIONS
PAGE 56-74



TIP-UP TAILS*

FOR ACCESS INSIDE CONVEYOR FOR CLEANING AND MAINTENANCE

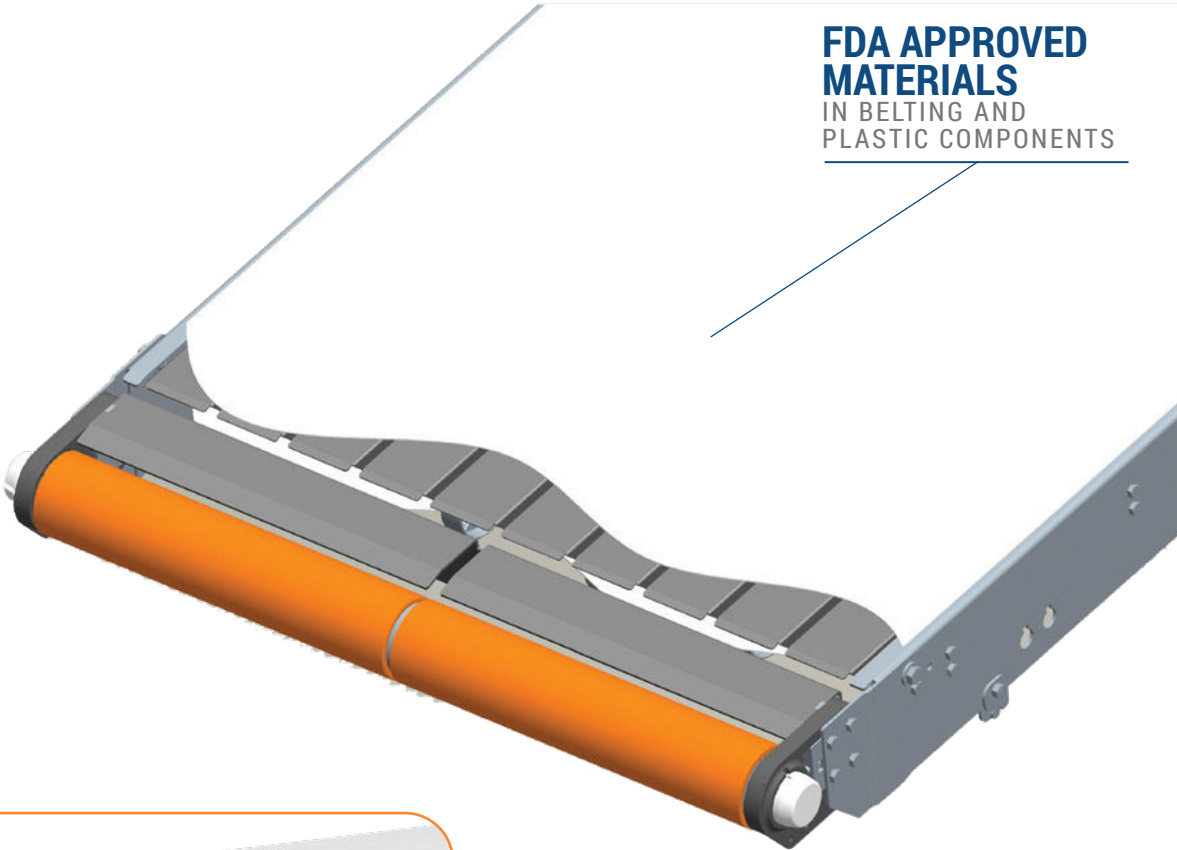

FDA APPROVED MATERIALS

IN BELTING AND PLASTIC COMPONENTS



NOSE BAR IDLER TAILS

WITH V-GUIDE TRACKING

ROBUST OPEN LEG SUPPORT STANDS

7 GAUGE WELDED STAINLESS STEEL



*Note: Do not run the conveyor with the tail in the tip-up position.

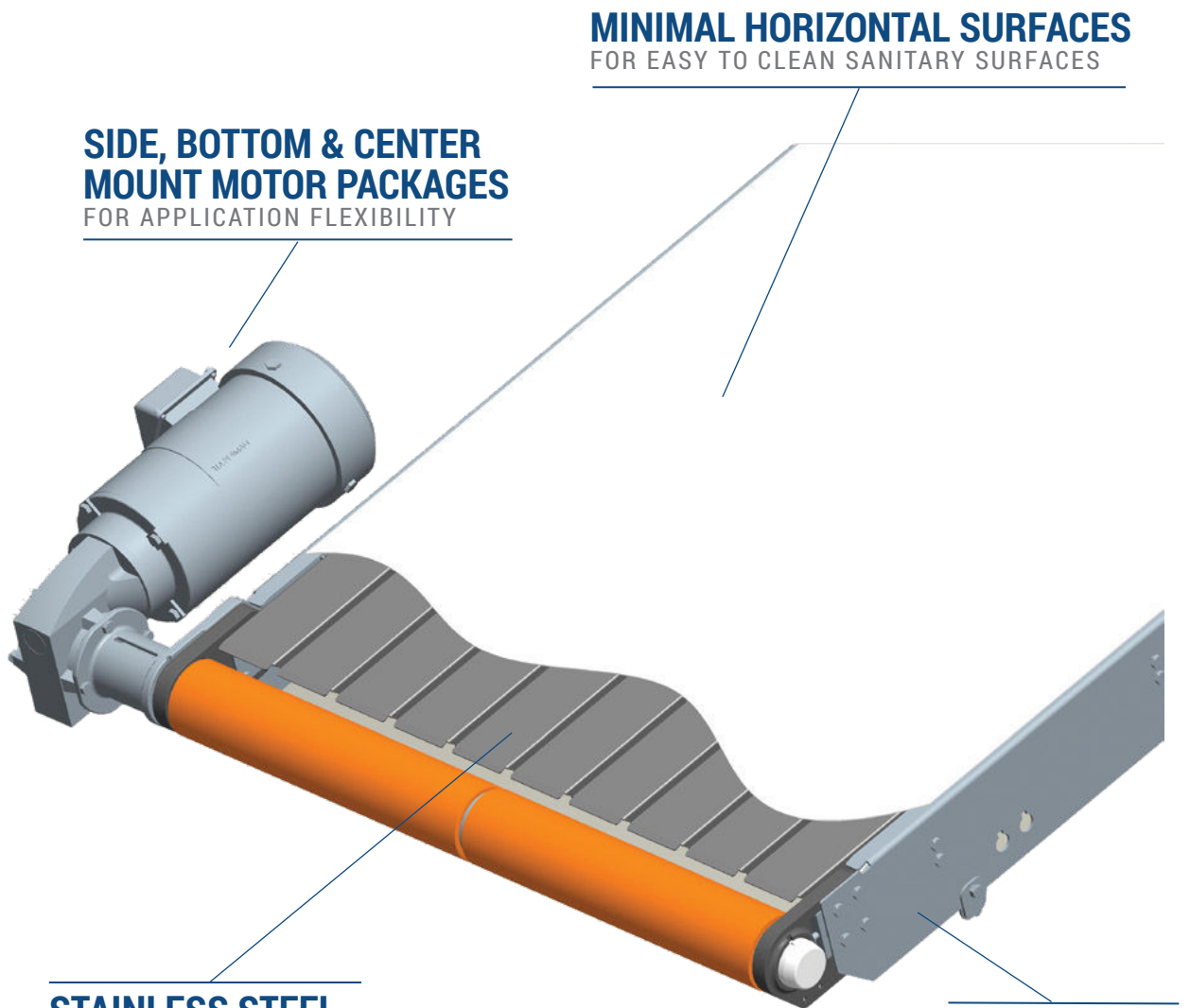

SIDE, BOTTOM & CENTER MOUNT MOTOR PACKAGES
FOR APPLICATION FLEXIBILITY

MINIMAL HORIZONTAL SURFACES
FOR EASY TO CLEAN SANITARY SURFACES

STAINLESS STEEL BED RAILS
SEGMENTED TO MINIMIZE BELT "STICK-TION" IN WET APPLICATIONS

FLAT SIDES
ALLOW FOR FLEXIBILITY WHEN MOUNTING ACCESSORIES, INTERFACING WITH OTHER EQUIPMENT OR TRANSFERRING PRODUCTS



ROBUST STAINLESS GUIDING
BOLT-ON TO 150 MM (6 INCH) TALL



Specifications

- Loads up to 227 kg (500 lbs) or 98 kg/sq m (20 lbs/sq ft)*
- Belt speeds up to 91 m/min (300 ft/min)
- Belt widths: 152 mm (6 in) to 914 mm (36 in)
- Conveyor lengths: 915 mm (36 in) to 12190 mm (480 in)
- One revolution of drive pulley moves the belt approximately 280 mm (11 in)
- Bolt-together 304 Stainless Steel Frame
- Hard chrome coated bearing with FDA H1 food grade grease
- FDA approved belting and plastic components
- Open design with minimal horizontal surfaces
- Suitable for use in wet environments
- Stainless Steel construction for wipe down and low pressure washdown with non-caustic solutions
- V-guide belt tracking



**STANDARD FEATURE:
V-Guided Belt Tracking**



**OPTIONAL:
32 mm (1.25 in) Nose Bar Tail**



**STANDARD FEATURE:
Tip-Up Tail****

AquaGard 7350 Belted Flat Belt End Drive Conveyor

73 E M W W W - L L L L L V I A S S P P P P B B - X T¹ T²

— Conveyor Tail Options X (if required) *See Drive Shaft Position Chart on next page
K = Keyed Auxiliary Shaft Ø = No Keyed Auxiliary Shaft

— Belt Type: See Pages 21-25 for belt selection

— Profile (D side)

— Profile (A side)

01 = Low Side 04 = 75 mm (3 in) High Side 05 = 25 mm (1 in) High Side 06 = 152 mm (6 in) High Side
13 = Fully Adjustable Round 14 = Tool-less Fully Adjustable Round 17 = Fully Adjustable 32 mm (1.25 in) Flat
18 = Tool-less Fully Adjustable 25 mm (1 in) Flat

— Idler Stand Location: Note: Tip-up tail start at 18"
A = No Stand Mount Mounting brackets C = 457 mm (18 in) from end D = 610 mm (24 in) from end E = 762 mm (30 in) from end
F = 914 mm (36 in) from end H = 457 mm (18 in) from end with braces J = 610 mm (24 in) from end with braces
K = 762 mm (30 in) from end with braces M = 914 mm (36 in) from end with braces

— Drive Stand Location:
A = No Stand Mount Mounting brackets B = 305 mm (12 in) from end C = 457 mm (18 in) from end D = 610 mm (24 in) from end
G = 305 mm (12 in) from end with braces H = 457 mm (18 in) from end with braces J = 610 mm (24 in) from end with braces

— Drive Shaft Position: A, B, C or D

— Idler Tail Type: 1 = Standard, 2 = Nose Bar

— V-Guide Options: A = V-Guided Belt, B = Non V-Guided Belt

— Conveyor Length (mm): 00915 to 12190 in 5 mm increments (36 – 480 in)

— Conveyor Width Reference (mm): = 152 to 914 (6 – 36 in)

— Documentation Language: M = US English, U = Europe English, D = German, F = French, S = Spanish

* Conveyor load capacity depends on conveyor size, incline, motor position, accumulated loads and other factors.

** Note: Do not run the conveyor with the tail in the tip-up position.

Order gearmotor mounting packages and gearmotors separately, see pages 44-48.
For support stands and accessories, see page 50-55.

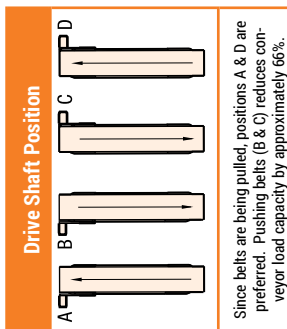
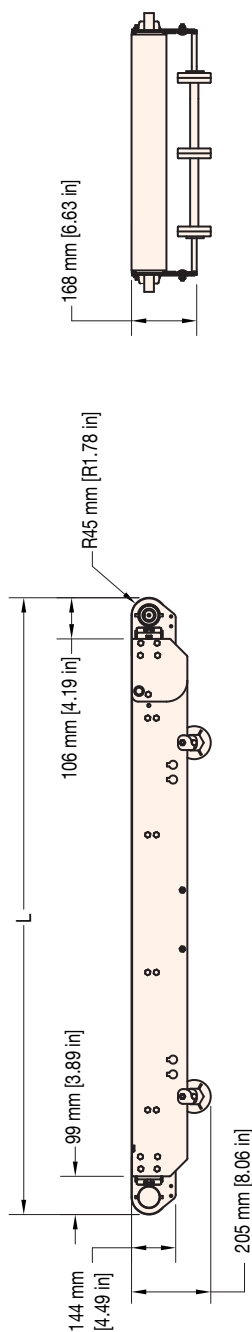
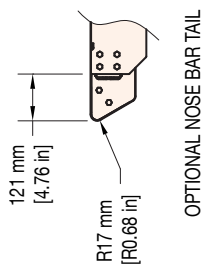
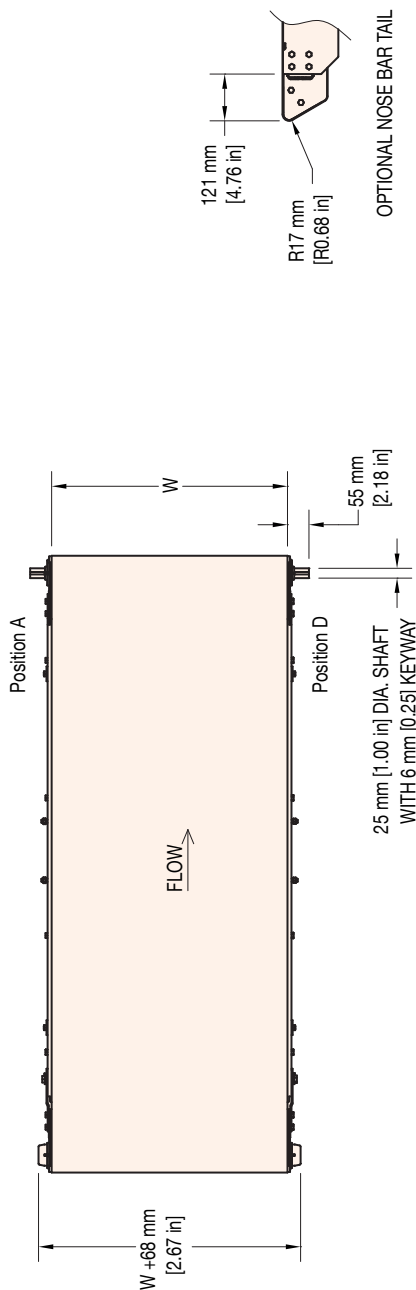

W = Conveyor Belt Width Dim = mm (in)

STANDARD SIZES

Conveyor Width Reference	152	203	254	305	356	406	457	508	559	610	660	711	762	813	864	914
Conveyor Belt Width (W)	152	203	254	305	356	406	457	508	559	610	660	711	762	813	864	914
	(6)	(8)	(10)	(12)	(14)	(16)	(18)	(20)	(22)	(24)	(26)	(28)	(30)	(32)	(34)	(36)
Conveyor Length Reference	00915															
Conveyor Length (L)	00915 (36)															
	00005 increments up to...															
	00005 (0.2) increments up to...															
	12190															
	12190 (480)															

Due to the wide variety of drive set ups and applications, point of installation guarding is the responsibility of the end user.



Specifications

- Loads up to 227 kg (500 lbs) or 98 kg/sq m (20 lbs/sq ft)*
- Belt speeds up to 91 m/min (300 ft/min)
- Belt widths: 152 mm (6 in) to 914 mm (36 in)
- Conveyor lengths: 1525 mm (60 in) to 25,000 mm (82 ft)
- Manual or Pneumatic center drive options
- Bolt-together 304 Stainless Steel Frame
- Hard chrome coated bearing with FDA H1 food grade grease
- FDA approved belting and plastic components
- Open design with minimal horizontal surfaces
- Suitable for use in wet environments
- Stainless Steel construction for wipe down and low pressure washdown with non-caustic solutions



**STANDARD FEATURE:
V-Guided Belt Tracking**



**OPTIONAL:
32 mm (1.25 in) Nose Bar Tail**



**STANDARD FEATURE:
Tip-Up Tail****

AquaGard 7350 Belted Flat Belt Center Drive Conveyor

73 M M W W W - L L L L L V 1 A S S P P P P B B M - X T¹ T²

— Conveyor Tail Options X (if required) *See Drive Shaft Position Chart on next page
 K = Keyed Auxiliary Shaft Ø = No Keyed Auxiliary Shaft

— Center Drive Tension Type: P = Pneumatic, M = Manual

— Belt Type: See Pages 21-25 for belt selection

— Profile (D side)

— Profile (A side)
 01 = Low Side 04 = 75 mm (3 in) High Side 05 = 25 mm (1 in) High Side 06 = 152 mm (6 in) High Side
 13 = Fully Adjustable Round 14 = Tool-less Fully Adjustable Round 17 = Fully Adjustable 32 mm (1.25 in) Flat
 18 = Tool-less Fully Adjustable 25 mm (1 in) Flat

— Idler Stand Location: Note: Tip-up tail start at 18"
 A = No Stand Mount Mounting brackets C = 457 mm (18 in) from end D = 610 mm (24 in) from end E = 762 mm (30 in) from end
 F = 914 mm (36 in) from end H = 457 mm (18 in) from end with braces J = 610 mm (24 in) from end with braces
 K = 762 mm (30 in) from end with braces M = 914 mm (36 in) from end with braces

— Drive Stand Location:
 A = No Stand Mount Mounting brackets B = 305 mm (12 in) from end C = 457 mm (18 in) from end D = 610 mm (24 in) from end
 G = 305 mm (12 in) from end with braces H = 457 mm (18 in) from end with braces J = 610 mm (24 in) from end with braces

— Drive Shaft Position: A or D

— Fixed / Idler Tail Option: 1 = Standard / Standard, 2 = Nosebar / Nosebar, 3 = Standard / Nosebar, 4 = Nosebar / Standard

— V-Guide Options: A = V-Guided Belt, B = Non V-Guided Belt

— Conveyor Length (mm): 1525 to 25000 in 5 mm increments (60 – 984 in)

— Conveyor Width Reference (mm): = 152 to 914 (6 – 36 in)

— Documentation Language: M = US English, U = Europe English, D = German, F = French, S = Spanish

* Conveyor load capacity depends on conveyor size, incline, motor position, accumulated loads and other factors.

** Note: Do not run the conveyor with the tail in the tip-up position.

Order gearmotor mounting packages and gearmotors separately, see pages 44-48.
 For support stands and accessories, see page 50-55.

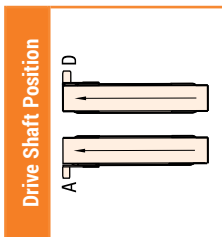
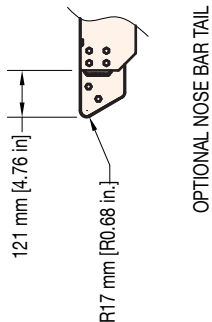
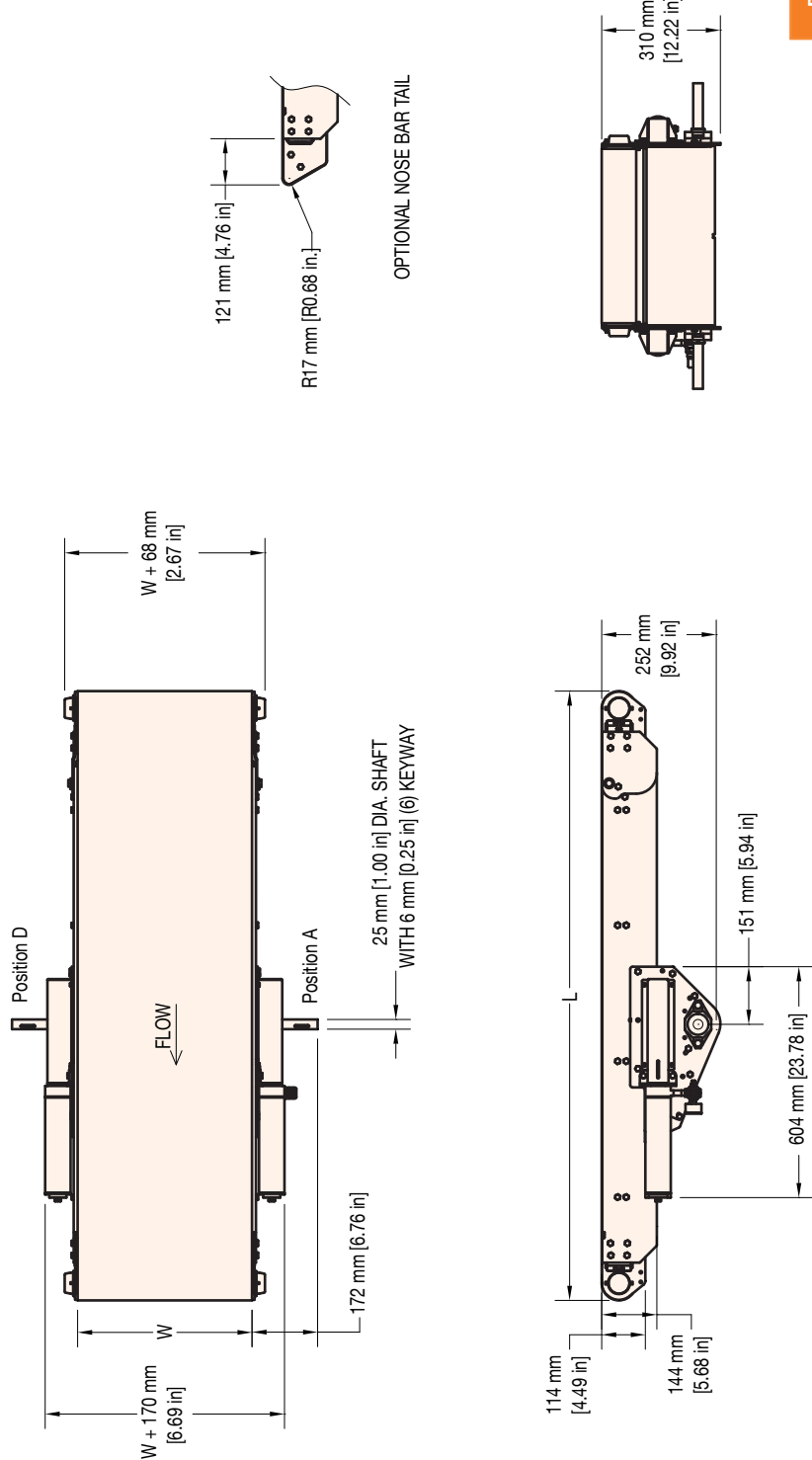

W = Conveyor Belt Width Dim = mm (in)

STANDARD SIZES																
Conveyor Width Reference	152	203	254	305	356	406	457	508	559	610	660	711	762	813	864	914
Conveyor Belt Width (W)	152 (6)	203 (8)	254 (10)	305 (12)	356 (14)	406 (16)	457 (18)	508 (20)	559 (22)	610 (24)	660 (26)	711 (28)	762 (30)	813 (32)	864 (34)	914 (36)
Conveyor Length Reference	01525															
Conveyor Length (L)	01525 (60)															
	00005 increments up to...															
	00005 (0.2) increments up to...															
	25000															
	25000 (984)															

Due to the wide variety of drive set ups and applications, point of installation guarding is the responsibility of the end user.

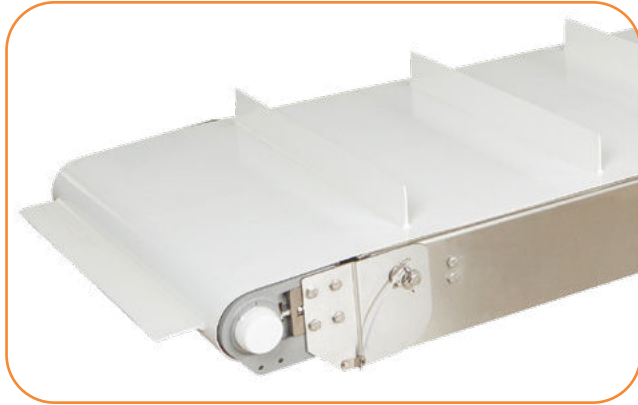

Specifications

- Loads up to 227 kg (500 lbs) or 98 kg/sq m (20 lbs/sq ft)*
- Belt speeds up to 91 m/min (300 ft/min)
- Belt widths: 152 mm (6 in) to 610 mm (24 in)
- Conveyor lengths: 915 mm (36 in) to 12190 mm (480 in)
- Cleat heights from 11 mm (0.43 in) to 60 mm (2.63 in)
- Bolt-together 304 Stainless Steel Frame
- Hard chrome coated bearing with FDA H1 food grade grease
- FDA approved belting and plastic components
- Cleated belt options include sealed edge, encased and sidewall cleating
- Open design with minimal horizontal surfaces
- Suitable for use in wet environments
- Stainless Steel construction for wipe down and low pressure washdown with non-caustic solutions

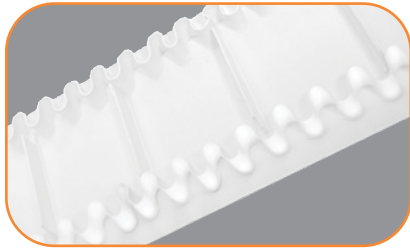

OPTIONAL:
Sidewall Cleated Belts
for Small Parts



STANDARD FEATURE:
V-Guided Belt Tracking



OPTIONAL: High Side Guides
Up to 152 mm (6 in) Tall

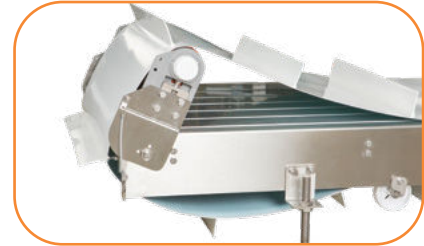

STANDARD FEATURE:
Tip-Up Tail**

AquaGard 7350 Cleated Belt Conveyor

73 C M W W W - L L L L L V D A S S P B S S S S - X T¹ T²

— Conveyor Tail Options X (if required) *See Drive Shaft Position Chart on next page
K = Keyed Auxiliary Shaft Ø = No Keyed Auxiliary Shaft

— Spacing: SSSS in millimeters

— Belt/Cleat Type: See Pages 21-25 for belt selection

— Profile:
0 = Low Side 2 = Cleated 25 mm (1 in) Bolt On High Side 3 = Cleated 75 mm (3 in) Bolt On High Side
6 = Cleated 152 mm (6 in) bolt on high side

— Idler Stand Location: Note: Tip-up tail start at 18"
A = No Stand Mount Mounting brackets C = 457 mm (18 in) from end D = 610 mm (24 in) from end E = 762 mm (30 in) from end
F = 914 mm (36 in) from end H = 457 mm (18 in) from end with braces J = 610 mm (24 in) from end with braces
K = 762 mm (30 in) from end with braces M = 914 mm (36 in) from end with braces

— Drive Stand Location:
A = No Stand Mount Mounting brackets B = 305 mm (12 in) from end C = 457 mm (18 in) from end D = 610 mm (24 in) from end
G = 305 mm (12 in) from end with braces H = 457 mm (18 in) from end with braces J = 610 mm (24 in) from end with braces

— Drive Shaft Position: A, B, C, or D

— Drive Tail Option: 1 = Standard Bottom / Side

— V-Guide Options: A = V-Guided Belt, B = Non V-Guided Belt

— Conveyor Length (mm): 00915 to 12190 in 5 mm increments (36 - 480 in)

— Conveyor Width Reference (mm): = 152 to 610 (6 - 24 in)

— Documentation Language: M = US English, U = Europe English, D = German, F = French, S = Spanish

* Conveyor load capacity depends on conveyor size, incline, motor position, accumulated loads and other factors.

** Note: Do not run the conveyor with the tail in the tip-up position.

Order gearmotor mounting packages and gearmotors separately, see pages 44-48.
For support stands and accessories, see page 50-55.

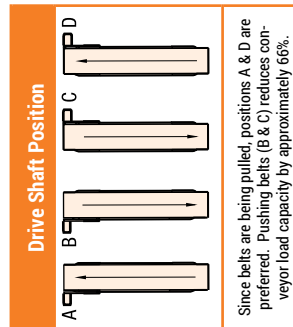
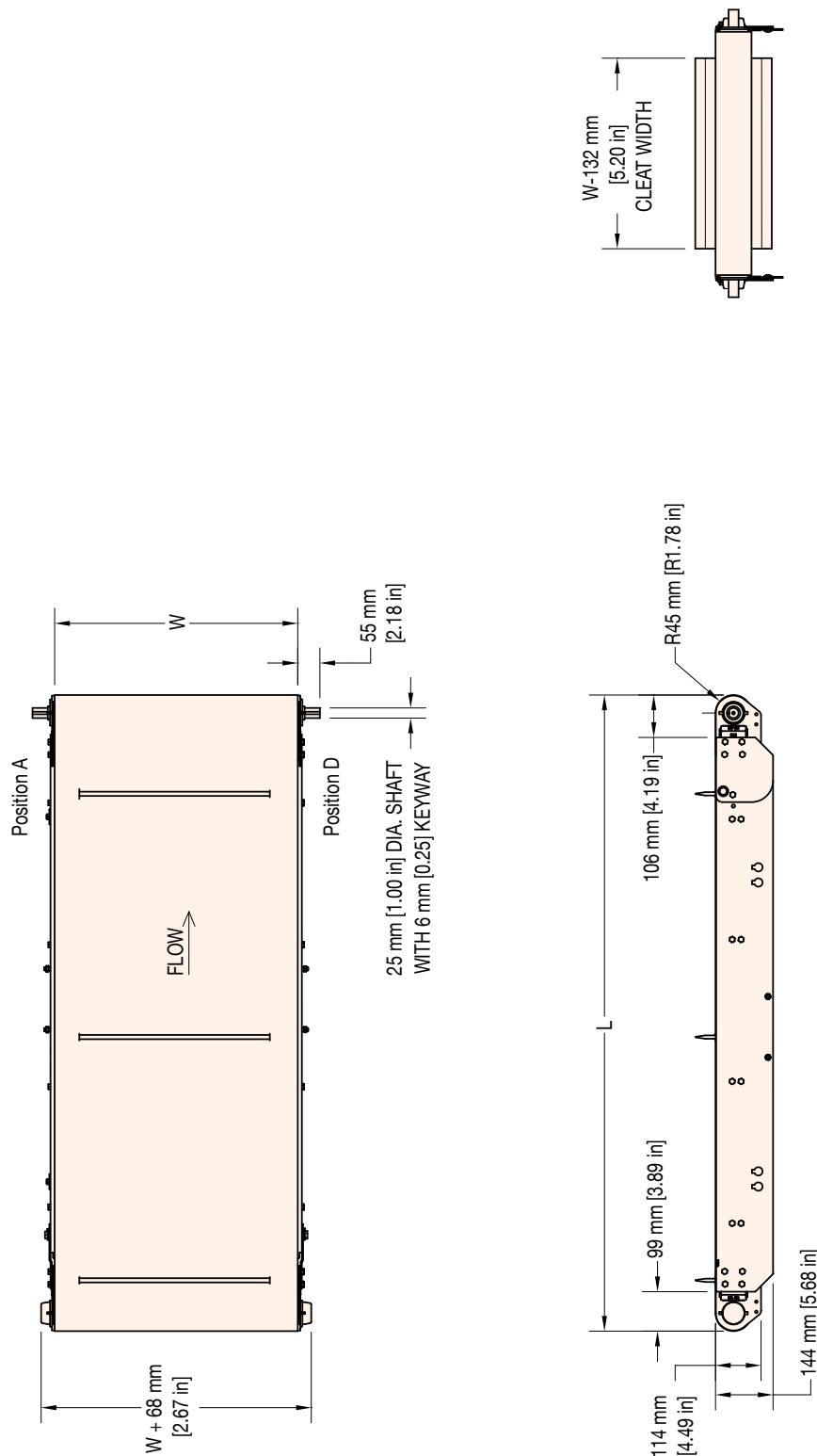

W = Conveyor Belt Width Dim = mm (in)

STANDARD SIZES											
Conveyor Width Reference	152	203	254	305	356	406	457	508	559	610	
Conveyor Belt Width (W)	152	203	254	305	356	406	457	508	559	610	
	(6)	(8)	(10)	(12)	(14)	(16)	(18)	(20)	(22)	(24)	
Conveyor Length Reference	00915		00005 increments up to...								12190
Conveyor Length (L)	0915 (36)		00005 (0.2) increments up to...								12190 (480)

Note: If conveyor width ≥ 457 then the max length is 2135

Due to the wide variety of drive set ups and applications, point of installation guarding is the responsibility of the end user.



Specifications

- Loads up to 227 kg (500 lbs) or 98 kg/sq m (20 lbs/sq ft)*
- Belt speeds up to 91 m/min (300 ft/min)
- Belt widths: 152 mm (6 in) to 610 mm (24 in)
- Conveyor section lengths: 610 mm (24 in) to 6100 mm (240 in)
- Maximum total conveyor length of 12190 mm (480 in)
- Angles from 5 degrees to 30 degrees in 5 degree increments
- Bolt-together 304 Stainless Steel Frame
- Hard chrome coated bearing with FDA H1 food grade grease
- FDA approved belting and plastic components
- V-guided belt for optimum performance
- Suitable for use in wet environments
- Stainless Steel construction for wipe down and low pressure washdown with non-caustic solutions

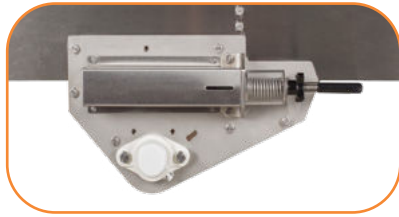

**OPTIONAL:
Center Drive Module**

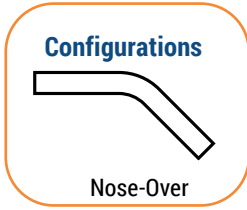

Configurations

Nose-Over



**STANDARD FEATURE:
V-Guided Belt Tracking**



**OPTIONAL:
32 mm (1.25 in) Nose Bar Tail**



**STANDARD FEATURE:
Tip-Up Tail****

AquaGard 7350 Z-Frame Flat Belt Conveyor																												
73	E	M	W	W	-	L	L	L	L	-	L	L	L	L	A	A	E	V	I	A	S	S	P	B	-	X	T	T
<p>— Conveyor Tail Options X (if required) *See Drive Shaft Position Chart on next page K = Keyed Auxiliary Shaft Ø = No Keyed Auxiliary Shaft</p> <p>— Belt Type: See Pages 21-25 for belt selection</p> <p>— Profile: 0 = Low Side 4 = 75mm (3 in) High Side 5 = 25mm (1 in) High Side 6 = 152mm (6 in) High Side 13 = Fully Adjustable Round 14 = Tool-less Fully Adjustable Round 17 = Fully Adjustable 32mm (1.25 in) Flat 18 = Tool-less Fully Adjustable 25mm (1 in) Flat</p> <p>— Idler Stand Location: Note: Tip-up tail start at 18" A = No Stand Mount Mounting brackets C = 457 mm (18 in) from end D = 610 mm (24 in) from end E = 762 mm (30 in) from end F = 914 mm (36 in) from end H = 457 mm (18 in) from end with braces J = 610 mm (24 in) from end with braces K = 762 mm (30 in) from end with braces M = 914 mm (36 in) from end with braces</p> <p>— Drive Stand Location: A = No Stand Mount Mounting brackets B = 305 mm (12 in) from end C = 457 mm (18 in) from end D = 610 mm (24 in) from end G = 305 mm (12 in) from end with braces H = 457 mm (18 in) from end with braces J = 610 mm (24 in) from end with braces</p> <p>— Drive Shaft Position: A, B, C, or D</p> <p>— Drive Tail Option: 1 = Standard, 2 = Nose Bar</p> <p>— V-Guide Options: A = V-Guided Belt (all LPZ must be V-guide)</p> <p>— Belt Direction: E = Inclining, D = Declining</p> <p>— Angle: 05 degrees thru 30 degrees in 05 degree increments</p> <p>— Conveyor L2 Upper Horizontal Section Length (mm): 0610 to 6100 (24 – 240 in)</p> <p>— Conveyor L1 Upper Horizontal Section Length (mm): 0610 to 6100 (24 – 240 in)</p> <p>— Conveyor Width Reference (mm): = 152 to 610 (6 – 24 in)</p> <p>— Documentation Language: M = US English, U = Europe English, D = German, F = French, S = Spanish</p>																												

* Conveyor load capacity depends on conveyor size, incline, motor position, accumulated loads and other factors.

** Note: Do not run the conveyor with the tail in the tip-up position.

Order gearmotor mounting packages and gearmotors separately, see pages 44-48.
 For support stands and accessories, see page 50-55.

LPZ (Z-FRAME) FLAT BELT END DRIVE

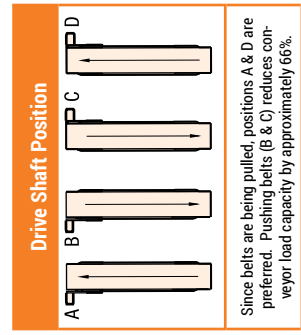
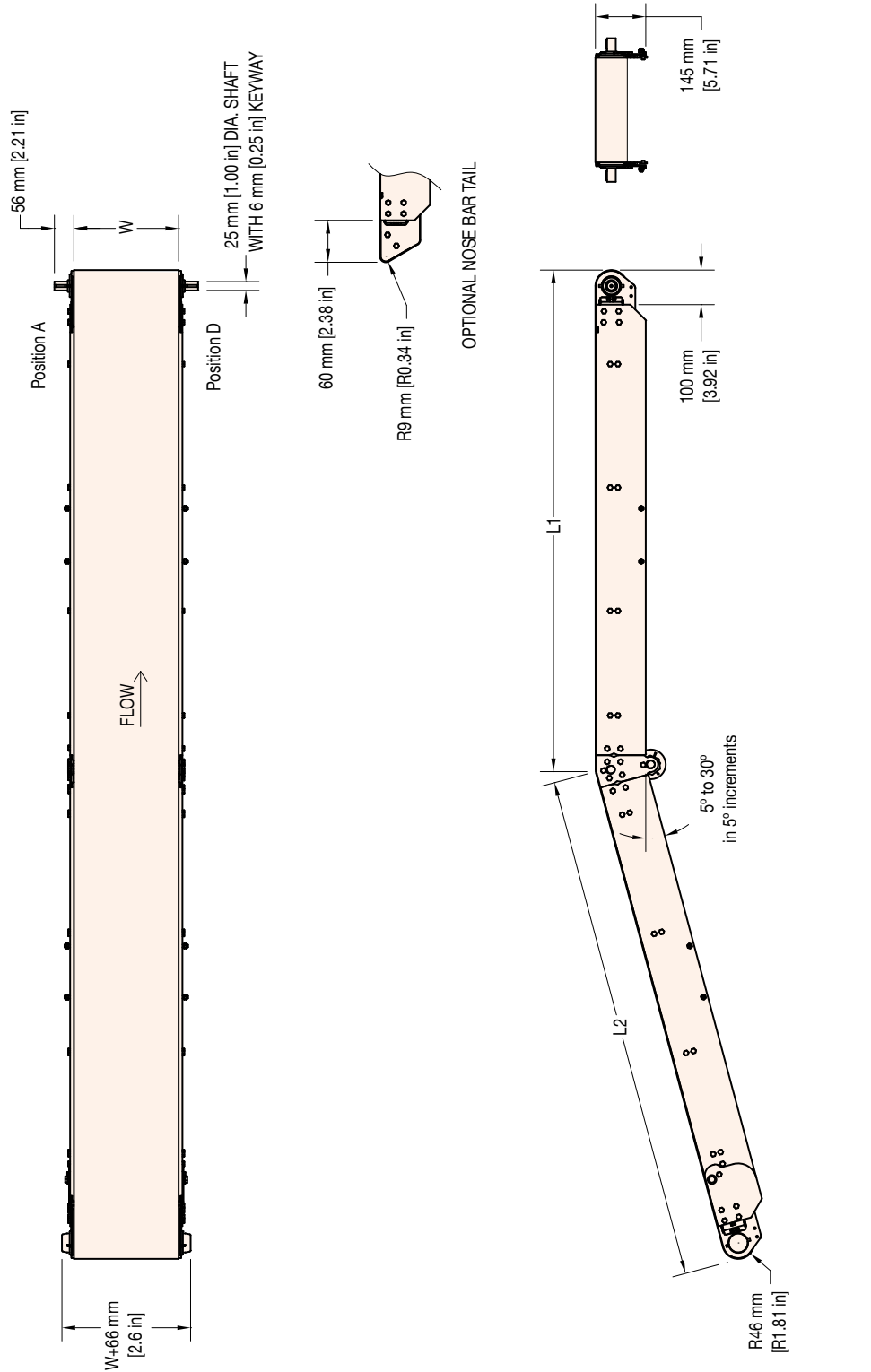

W = Conveyor Belt Width Dim = mm (in)

STANDARD SIZES										
Conveyor Width Reference	152	203	254	305	356	406	457	508	559	610
Conveyor Belt Width (W)	152	203	254	305	356	406	457	508	559	610
	(6)	(8)	(10)	(12)	(14)	(16)	(18)	(20)	(22)	(24)
Conveyor Length Reference	0610		00005 increments up to...							
Conveyor Length (L1/L2/L3)	0610 (24)	00005 (0.2) increments up to...								
										6100 (240)

Due to the wide variety of drive set ups and applications, point of installation guarding is the responsibility of the end user.



Specifications

- Loads up to 45 kg (100 lbs) or 98 kg/sq m (20 lbs/sq ft)*
- Belt speeds up to 91 m/min (300 ft/min)
- Belt widths: 152 mm (6 in) to 610 mm (24 in)
- Conveyor section lengths: 610 mm (24 in) to 6100 mm (240 in)
- Maximum total conveyor length of 12190 mm (480 in)
- Angles from 30 degrees to 60 degrees in 5 degree increments
- Cleat heights from 11 mm (0.43 in) to 60 mm (2.63 in)
- Bolt-together 304 Stainless Steel Frame
- Hard chrome coated bearing with FDA H1 food grade grease
- FDA approved belting and plastic components
- Cleated belt options include sealed edge, encased and sidewall cleating
- Open design with minimal horizontal surfaces
- Suitable for use in wet environments
- Stainless Steel construction for wipe down and low pressure washdown with non-caustic solutions

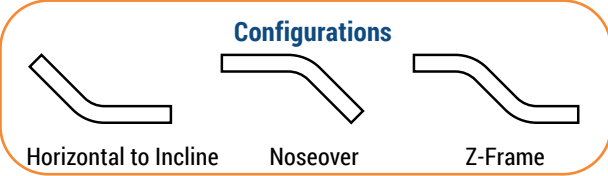

Configurations

Horizontal to Incline Noseover Z-Frame



OPTIONAL: Sidewall Cleated Belts for Small Parts



STANDARD FEATURE:
V-Guided Belt Tracking



OPTIONAL:
High Side Guides

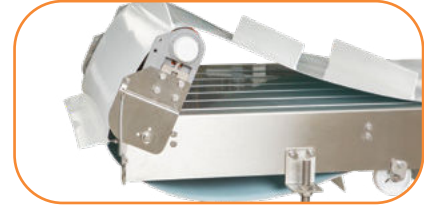

STANDARD FEATURE:
Tip-Up Tail**

AquaGard 7350 Z-Frame Cleated Conveyor

73 C M W W W - L L L L - L L L L - L L L L A A E V A D D P B S S S S - X T¹ T²

— Conveyor Tail Options X (if required) *See Drive Shaft Position Chart on next page
K = Keyed Auxiliary Shaft Ø = No Keyed Auxiliary Shaft

— Spacing: SSSS in millimeters

— Belt/Cleat Type: See Pages 21-25 for belt selection

— Profile: 0 = Low Side 2 = Cleated 25mm (1 in) Bolt On High Side 3 = Cleated 75mm (3 in) Bolt On High Side
6 = Cleated 152mm (6 in) Bolt on High Side

— Idler Stand Location: Note: Tip-up tail start at 18 in
A = No Stand Mount Mounting brackets C = 457 mm (18 in) from end D = 610 mm (24 in) from end
E = 762 mm (30 in) from end F = 914 mm (36 in) from end H = 457 mm (18 in) from end with braces
J = 610 mm (24 in) from end with braces K = 762 mm (30 in) from end with braces
M = 914 mm (36 in) from end with braces

— Drive Stand Location:
A = No Stand Mount Mounting brackets B = 305 mm (12 in) from end C = 457 mm (18 in) from end
D = 610 mm (24 in) from end G = 305 mm (12 in) from end with braces H = 457 mm (18 in) from end with braces
J = 610 mm (24 in) from end with braces

— Drive Shaft Position: A, B, C, or D

— V-Guide Options: A = V-Guided Belt (all LPZ must be V-guide)

— Belt Direction: E = Inclining, D = Declining

— Angle: 30 degrees thru 60 degrees in 05 degree increments

— Conveyor L3 Lower Horizontal Section Length (mm): 0610 - 6100 (24 - 240 in)

— Conveyor L2 Angled Section Length (mm): 0610 - 6100 (24 - 240 in)

— Conveyor L1 Upper Horizontal Section Length (mm): 0610 - 6100 (24 - 240 in)

— Conveyor Width Reference (mm): = 152 to 610 (6 - 24 in)

— Documentation Language: M = US English, U = Europe English, D = German, F = French, S = Spanish

* Conveyor load capacity depends on conveyor size, incline, motor position, accumulated loads and other factors.

** Note: Do not run the conveyor with the tail in the tip-up position.

Order gearmotor mounting packages and gearmotors separately, see pages 44-48.
For support stands and accessories, see page 50-55.

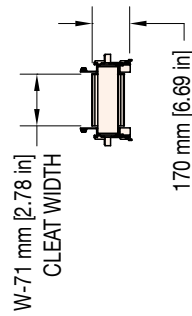
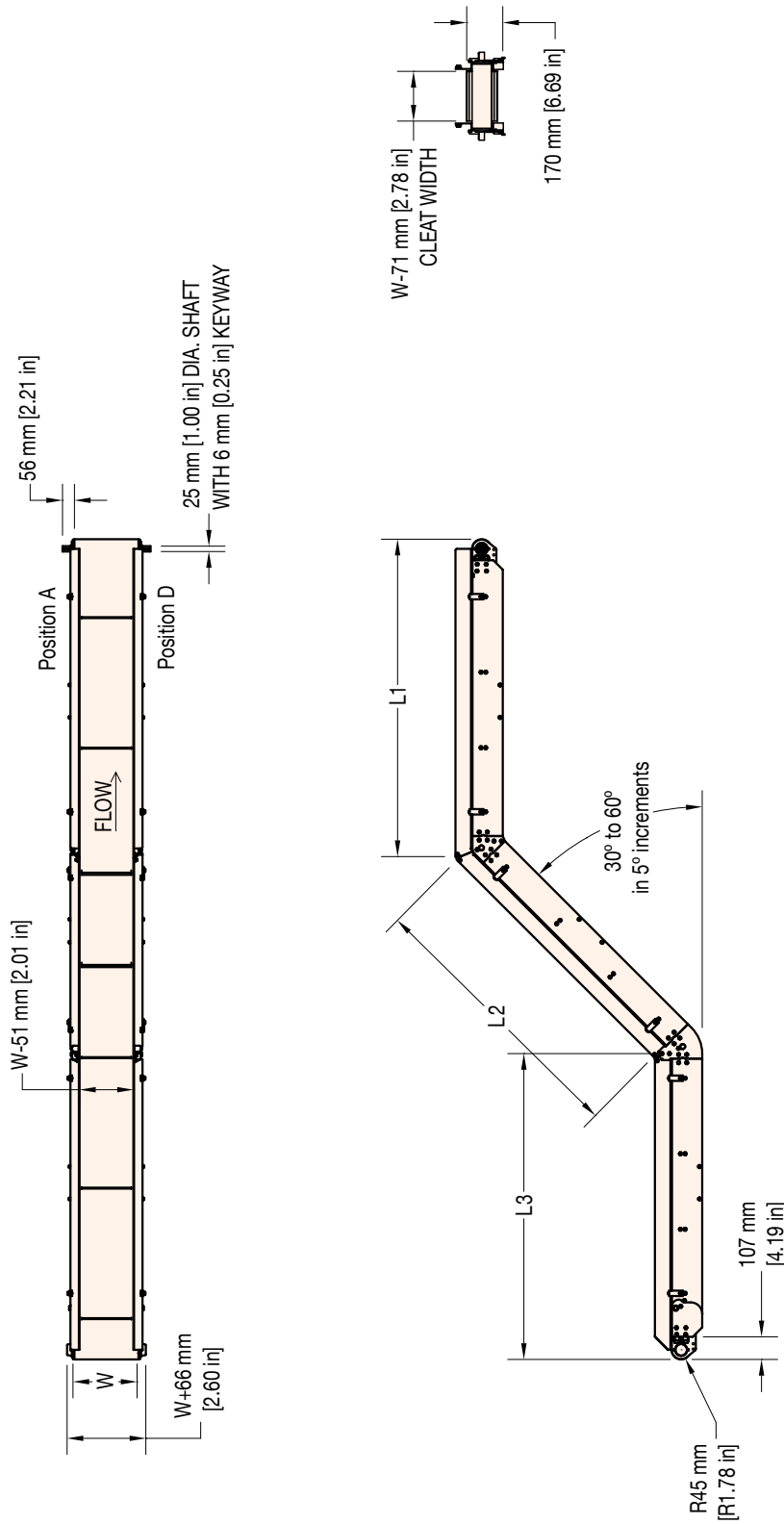

W = Conveyor Belt Width Dim = mm (in)

STANDARD SIZES		00005 (0.2) increments up to...		00005 increments up to...						
Conveyor Width Reference	152	203	254	305	356	406	457	508	559	610
Conveyor Belt Width (W)	152	203	254	305	356	406	457	508	559	610
Conveyor Length Reference	(6)	(8)	(10)	(12)	(14)	(16)	(18)	(20)	(22)	(24)
Conveyor Length (L1/L2/L3)	0610	0610 (24)	00005 increments up to...		00005 increments up to...		00005 increments up to...		6100 (240)	

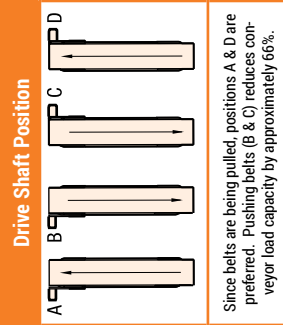

Since belts are being pulled, positions A & D are preferred. Pushing belts (B & C) reduces conveyor load capacity by approximately 66%.

Due to the wide variety of drive set ups and applications, point of installation guarding is the responsibility of the end user.

Note: If conveyor width \geq 457 mm then the max length is 2135 mm.
Max total length of all sections 12190 mm (480 in).

**FDA APPROVED
MATERIALS**
IN BELTING AND PLASTIC
COMPONENTS

**UHMW WEAR STRIP
BED PLATE**
ABRASION RESISTANT
MATERIALS SUPPORT BELT.
TOOL-LESS REMOVAL FOR
EASE OF CLEANING

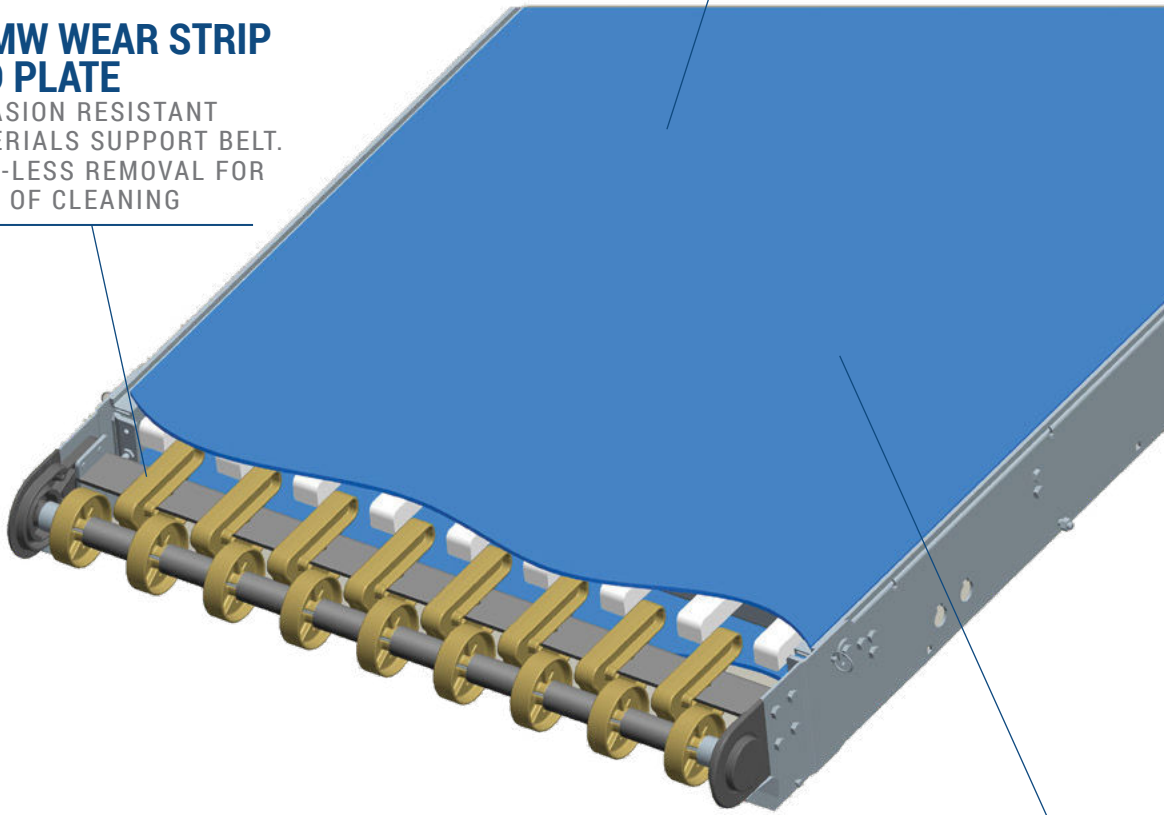

**USDA ACCEPTED
BELTING**
SOLID URETHANE WON'T
ABSORB WATER

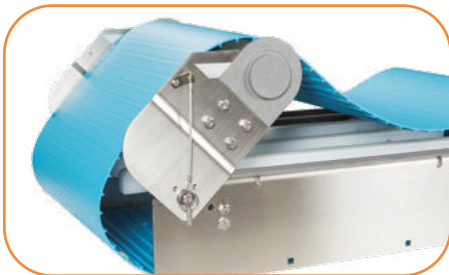

TIP-UP TAILS*
FOR ACCESS INSIDE CONVEYOR FOR
CLEANING AND MAINTENANCE

*Note: Do not run the conveyor with the tail in the tip-up position.

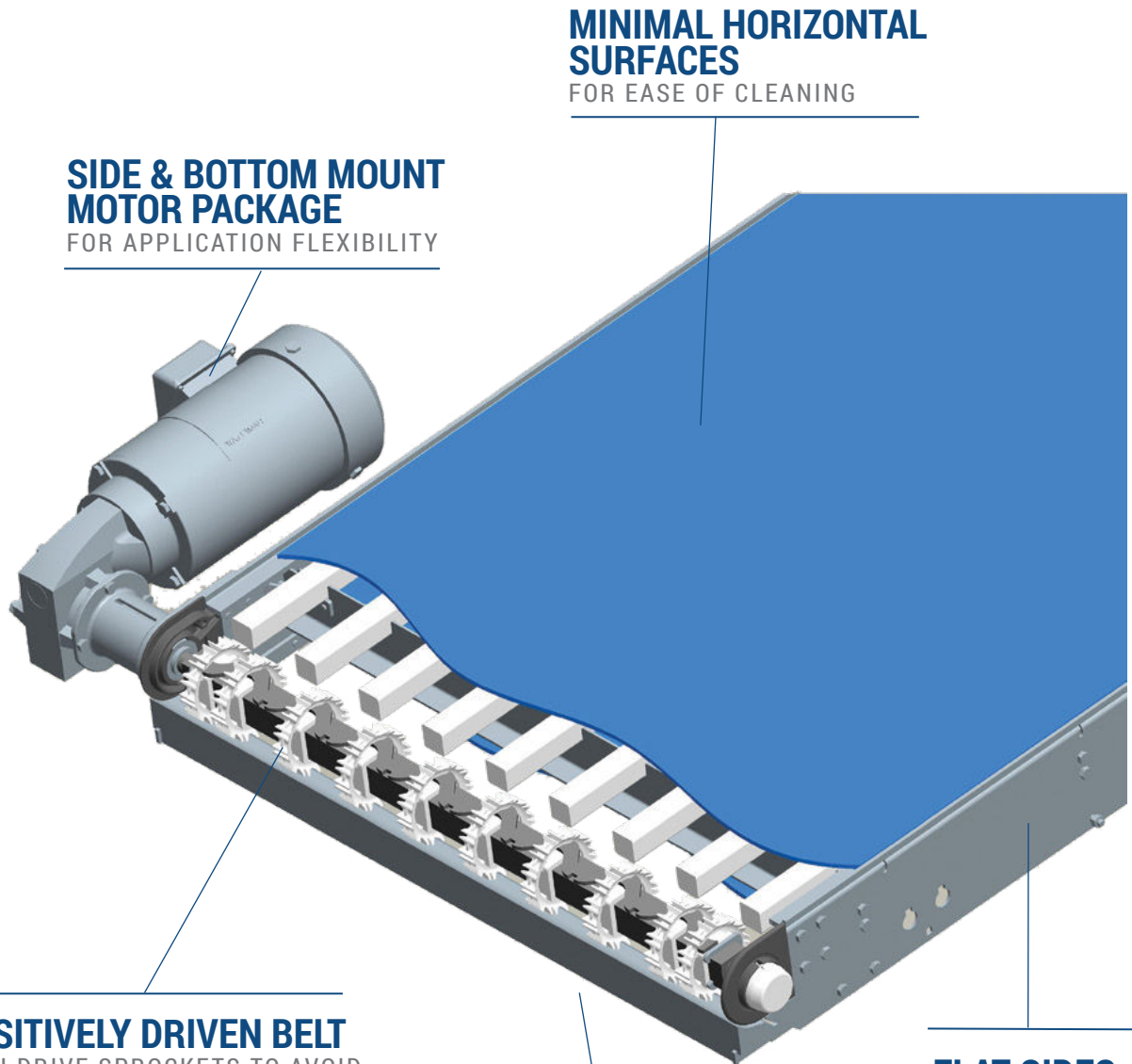

SIDE & BOTTOM MOUNT MOTOR PACKAGE
FOR APPLICATION FLEXIBILITY

MINIMAL HORIZONTAL SURFACES
FOR EASE OF CLEANING

POSITIVELY DRIVEN BELT
WITH DRIVE SPROCKETS TO AVOID SLIPPING IN WET ENVIRONMENTS

FLAT SIDES
ALLOW FOR FLEXIBILITY WHEN MOUNTING ACCESSORIES, INTERFACING WITH OTHER EQUIPMENT OR TRANSFERRING PRODUCTS

INTEGRATED UHMW RETURN SHOE
PROVIDES POSITIVE BELT CONTROL AND SPROCKET ENGAGEMENT



ROBUST OPEN LEG SUPPORT STANDS
7 GAUGE WELDED STAINLESS STEEL

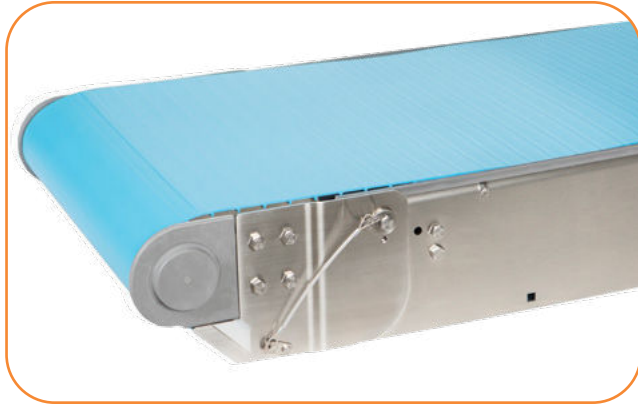

Specifications

- Loads up to 227 kg (500 lbs) or 98 kg/sq m (20 lbs/sq ft)*
- Belt speeds up to 71 m/min (233 ft/min)
- Belt widths: 152 mm (6 in) to 914 mm (36 in)
- Conveyor lengths: 915 mm (36 in) to 25,000 mm (82 ft)
- Positive driven belt provides greater load capacity and less slip
- Bolt-together 304 Stainless Steel Frame
- Hard chrome coated bearing with FDA H1 food grade grease
- USDA smooth top positive drive belt (Available in blue or white)
- Open design with minimal horizontal surfaces
- Suitable for use in wet environments
- Stainless Steel construction for wipe down and low pressure washdown with non-caustic solutions

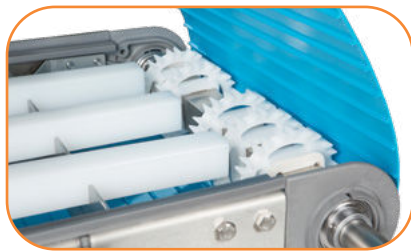

STANDARD FEATURE:
Positively driven drive sprockets and belt to avoid belt slipping

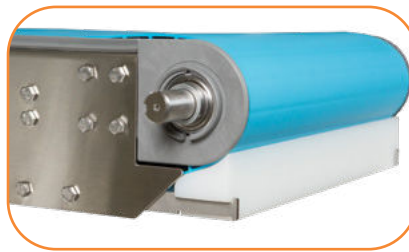

STANDARD FEATURE:
Integrated UHMW Return Shoe provides positive belt control and sprocket engagement

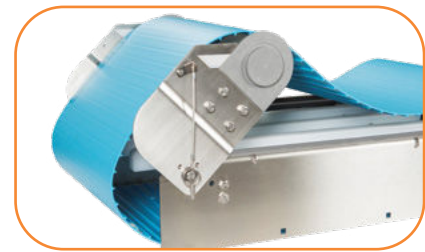

STANDARD FEATURE:
Tip-Up Tail**

AquaGard 7350 Belted Positive Drive Conveyor

73 P M W W W - L L L L L D A S S P P P P B B - X T¹ T²

— Conveyor Tail Options X (if required)
K = Keyed Shaft Ø = No Keyed Auxiliary Shaft

— Belt Type: 1 = Smooth Top, 2 = Smooth Top Blue See Page 25 for details

— Profile (D side)

— Profile (A side)
01 = Low Side 04 = 75 mm (3 in) High Side 05 = 25 mm (1 in) High Side 06 = 152 mm (6 in) High Side
13 = Fully Adjustable Round 14 = Tool-less Fully Adjustable Round 17 = Fully Adjustable 32 mm (1.25 in) Flat
18 = Tool-less Fully Adjustable 25 mm (1 in) Flat

— Idle Stand Location: Note: Tip-up tail start at 18°
A = No Stand Mount Mounting brackets C = 457 mm (18 in) from end D = 610 mm (24 in) from end E = 762 mm (30 in) from end
F = 914 mm (36 in) from end H = 457 mm (18 in) from end with braces J = 610 mm (24 in) from end with braces
K = 762 mm (30 in) from end with braces M = 914 mm (36 in) from end with braces

— Drive Stand Location:
A = No Stand Mount Mounting brackets B = 305 mm (12 in) from end C = 457 mm (18 in) from end D = 610 mm (24 in) from end
G = 305 mm (12 in) from end with braces H = 457 mm (18 in) from end with braces J = 610 mm (24 in) from end with braces

— Drive Shaft Position: A or D

— Drive Tail Type: 1 = Standard Bottom/Side

— Conveyor Length (mm): 00915 to 25000 in 5 mm increments (36 – 984 in)

— Conveyor Width Reference (mm): = 152 to 914 (6 – 36 in)

— Documentation Language: M = US English, U = Europe English, D = German, F = French, S = Spanish

* Conveyor load capacity depends on conveyor size, incline, motor position, accumulated loads and other factors.

** Note: Do not run the conveyor with the tail in the tip-up position.

Order gearmotor mounting packages and gearmotors separately, see pages 44-48.
For support stands and accessories, see page 50-55.

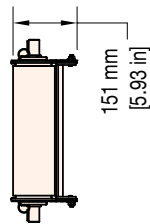
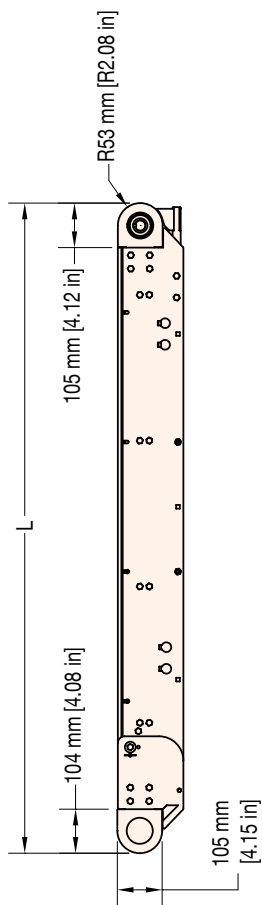
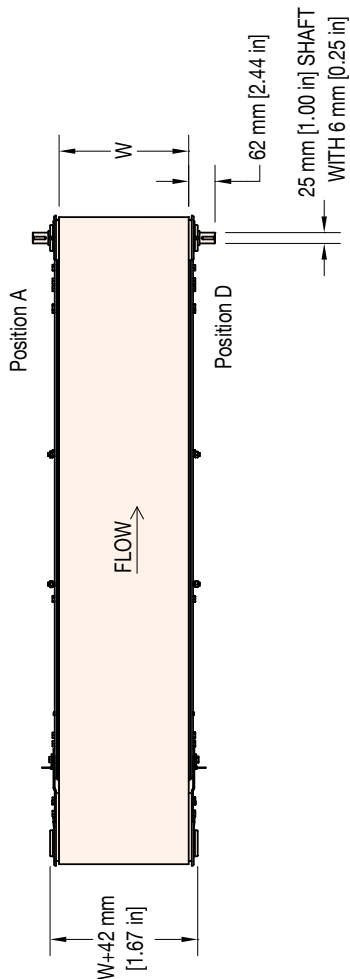

Drive Shaft Position

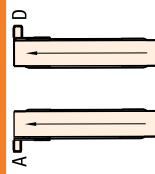

Since belts are being pulled, positions A & D are preferred. Pushing belts (B & C) reduces conveyor load capacity by approximately 66%.

W = Conveyor Belt Width Dim = mm (in)

STANDARD SIZES

Conveyor Width Reference	152	203	254	305	356	406	457	508	559	610	660	711	762	813	864	914
Conveyor Belt Width (W)	152 (6)	203 (8)	254 (10)	305 (12)	356 (14)	406 (16)	457 (18)	508 (20)	559 (22)	610 (24)	660 (26)	711 (28)	762 (30)	813 (32)	864 (34)	914 (36)
Conveyor Length Reference	00915															
Conveyor Length (L)	00915 (36)															
	00005 increments up to...															
	00005 (0.2) increments up to...															
	25000															
	25000 (984)															

Due to the wide variety of drive set ups and applications, point of installation guarding is the responsibility of the end user.

FLAT BELT PROFILES

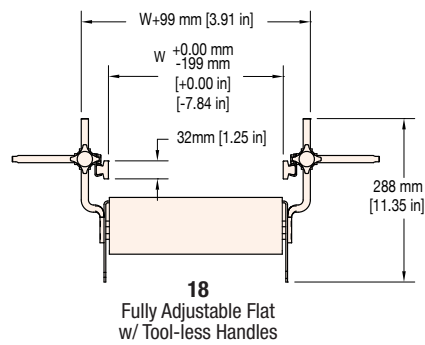
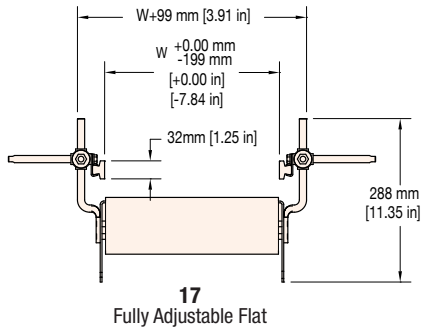
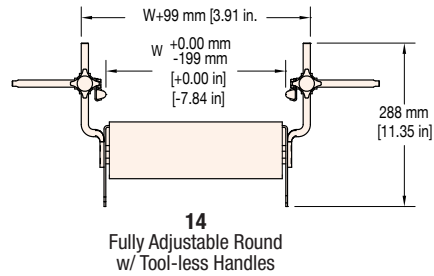
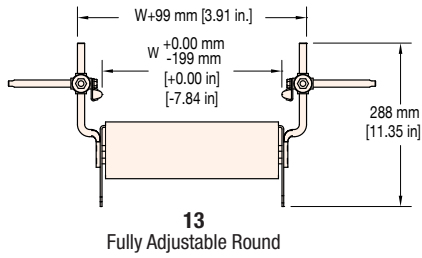
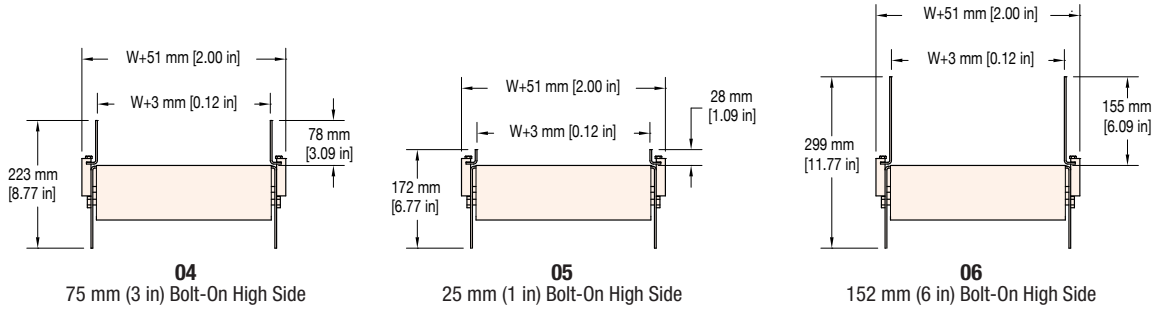

CLEATED BELT PROFILES

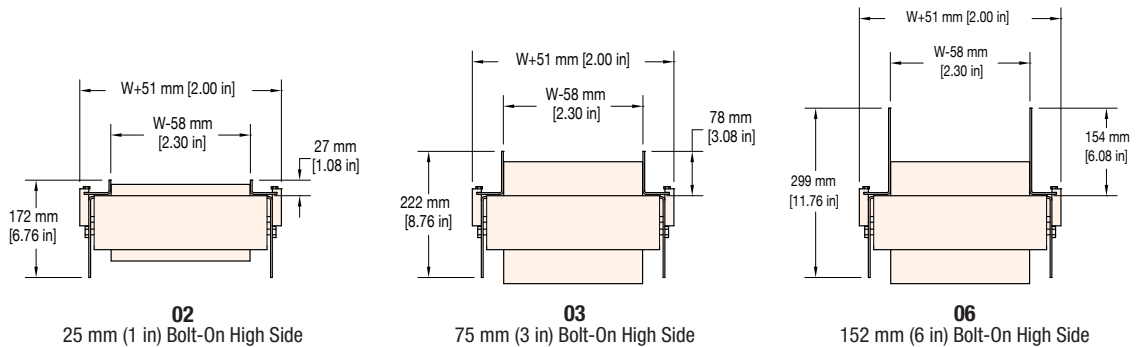

W = Conveyor Belt Width Dim = mm (in)

Due to the wide variety of drive set ups and applications, point of installation guarding is the responsibility of the end user.



Standard Belt Selection Guide

Standard belt material is stocked at Dornier, then cut & spliced at the factory for fast conveyor shipment.

Belt Type - Finger Splice	Belt Type - Plastic Clipper	Belt Type - Metal Clipper	Belt Specifications	V-Guidable	Belt Thickness	Surface Material	Maximum Part Temp. °C (°F)	Coefficient of Friction	FDA Approved	Anti-Static	ESD	Chemical Resistance	Special Characteristics or Applications
01	A1	1A	FDA Accumulation	x	1.7 (0.067)	Urethane	100 (212)	Low	x	x		Good	Packaging, clean room and inspection
02	A2	2A	General Purpose	x	1.8 (0.071)	Urethane	100 (212)	Med	x	x		Good	Most versatile belt offering
03	A3	3A	FDA High Friction	x	1.7 (0.067)	Urethane	100 (212)	High	x	x		Good	Packaging, clean room and inspection
05	A5	5A	Accumulation	x	1.2 (0.047)	Urethane	100 (212)	V-Low	x	x		Good	Accumulation of products
06	A6	6A	Static Dissipative	x	1.6 (0.063)	Urethane	80 (176)	V-Low		x	x	Good	Electronics handling
08	A8	8A	High Friction	x	2.1 (0.083)	PVC	70 (158)	V-High		x		Poor	Conveys up to 35° inclines*
09			FDA High Friction	x	1.5 (0.059)	Urethane	100 (212)	High	x			Good	Lower no load torque

Dim = mm (in)

Note: See below for splice details. Plastic Clipper splice requires longer lead times. Clipper splice not available on Z-Frame Series Conveyors.

Note: Belts with V-Guiding may have a slight high spot or rib on the top surface. This rib would run longitudinally along the center of the belt.

Consult factory with applications for which this may cause interference.

*Incline varies due to factors like dust, fluids and part material.

Note: Wet applications are limited to specialty belt types 54, 55, 69 and 70 only (see next page).

BELT SPLICING



Finger Splice

All belts are available with a standard Thermoformed finger splice. This splice makes the belt continuous and is virtually undetectable. Splice bonding methods vary by belt type. Consult factory for details.



Plastic Clipper**

An optional plastic clipper splice is available for quick removal of belts or when conveyors are installed in tight spaces.

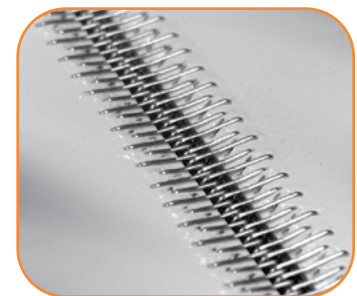

Metal Clipper**

An optional metal clipper splice is also available for quick removal of belts or when conveyors are installed in tight spaces.

** Plastic and Metal Clippers are slightly thicker than base belt. Contact factory for details.



Solid Urethane belt for added sanitary protection –
See belt type 70 below

High Release Cover belt for handling sticky food such as raw dough –
See belt type 71 below

Note: Wet applications are limited to specialty belt types 54, 55, 69 and 70 only.

Specialty Belt Selection Guide

Specialty belt material is not stocked at Dorner and needs to be custom ordered for your special conveyor needs.

Belt Type - Finger Splice	Belt Type - Plastic Clipper	Belt Type - Metal Clipper**	Belt Specifications	Belt Thickness	Surface Material	Maximum Part Temp. °C (°F)	Coefficient of Friction	FDA Approved	Chemical Resistance	Moisture Resistance	Special Characteristics or Applications
54	F4	4F	FDA Sealed Edge	1.5 (0.06)	Urethane	80 (176)	Low	x	Good	Good	Packaging, clean room & inspection, wet environment
55	F5	5F	FDA Sealed Edge	1.5 (0.06)	Urethane	80 (176)	High	x	Good	Good	Packaging, clean room & inspection, wet environment
56		6F	Cut Resistant	2.1 (0.08)	Urethane	100 (212)	Med.		Good	Poor	Oily product release, Metal stamping
57		7F	Cut Resistant	2.5 (0.10)	Nitrile	80 (176)	Med.		Poor	Poor	Felt-like, dry metal stamping, glass & ceramic
59	F9	9F	Color Contrasting	1.5 (0.06)	PVC	70 (158)	Med.		Poor	Poor	Black colored, hides overspray from ink jet
60	G0	0G	Color Contrasting	1.2 (0.05)	Urethane	100 (212)	Low	x	Good	Poor	Green colored, Nose Bar
61	G1	1G	Color Contrasting	1.2 (0.05)	Urethane	100 (212)	Low	x	Good	Poor	Blue colored, Nose Bar
63		3G	Electrically Conductive	1.2 (0.05)	Urethane	60 (140)	Low		Good	Poor	Static conductive, electronics handling
64		4G	High Friction	4.4 (0.17)	PVC	90 (194)	V-High		Poor	Poor	Dark Green colored, rough top surface, product cushioning, incline / decline apps
66		6G	Chemical Resistant	1.7 (0.07)	Polyester	100 (212)	Med.	x	V-Good	Poor	Good Cut resistance, metal stamping apps
67		7G	Low Friction Cleated	1.6 (0.06)	Polyester	100 (212)	n/a	x	Good	Poor	Excellent product release, consult factory for part number and how to specify low friction
68	G8		FDA Encased*	2.0 (0.08)	Urethane	100 (212)	Low	x	Good	V-Good	Urethane Enclosed for added sanitary protection
69	G9		FDA Encased*	2.0 (0.08)	Urethane	100 (212)	High	x	Good	V-Good	Urethane Enclosed for added sanitary protection
70			Solid Urethane	2.5 (0.10)	Urethane	100 (212)	Med.	x	Good	V-Good	USDA Approved, wet applications
71			High Release Cover	1.7 (0.07)	Urethane	100 (212)	Low	x	Good	Poor	Raw dough or sticky food product
72			Nose Bar Low Friction	1.2 (0.05)	Urethane	100 (212)	Low	x	Good	Poor	Nose Bar Applications

Dim = mm (in)
Metal Clipper Splices are not available on belts over 1219 mm (48 in) wide.
* Not available in 51 mm (2 in) wide.
**Metal Clipper splices are not sanitary.

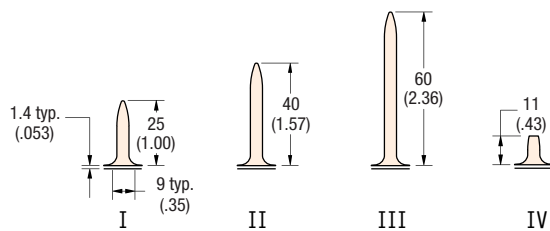

Standard Cleated Belt Selection Guide

Part No.	Base Belt	Belt Thickness, mm (in)	Belt Surface Material	Cleat Height, mm (in)	Cleat Material	Maximum Part Temp. °C (°F)	FDA Approved	Chemical Resistance	Moisture Resistance	Illustration
A	High Friction	1.4 (0.055)	Urethane	25 (1.00)	Urethane	80 (176)	Yes	Good	Poor	I
B	High Friction	1.4 (0.055)	Urethane	40 (1.57)	Urethane	80 (176)	Yes	Good	Poor	II
C	High Friction	1.4 (0.055)	Urethane	60 (2.36)	Urethane	80 (176)	Yes	Good	Poor	III
G	High Friction	1.4 (0.055)	Urethane	11 (0.43)	Urethane	80 (176)	Yes	Good	Poor	IV
J	Low Friction	1.6 (0.06)	Urethane	25 (1.00)	Urethane	100 (212)	Yes	Good	Poor	I
K	Low Friction	1.6 (0.06)	Urethane	40 (1.57)	Urethane	100 (212)	Yes	Good	Poor	II
L	Low Friction	1.6 (0.06)	Urethane	60 (2.36)	Urethane	100 (212)	Yes	Good	Poor	III
M	Low Friction	1.6 (0.06)	Urethane	11 (0.43)	Urethane	100 (212)	Yes	Good	Poor	IV

CLEATED BELT SPACING

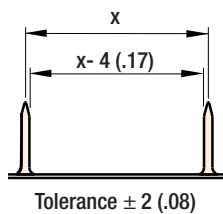

- Cleat spacing is determined by conveyor length and desired number of cleats
- Minimum spacing = 50 mm (2 in)
- Spacing accuracy = ± 2 mm (.08 in)
- Maximum 2135 mm (84 in) conveyor length for 487 mm (18 in) and wider conveyors
- Maximum 508 mm (20 in) cleat spacing for 2135 mm (84 in) and longer conveyors
- For Lengths > 7.3 m (24 ft) Tolerance ± 5 mm [.20 in]

Dim = mm (in)

SPECIALTY CLEATED BELT PROFILES

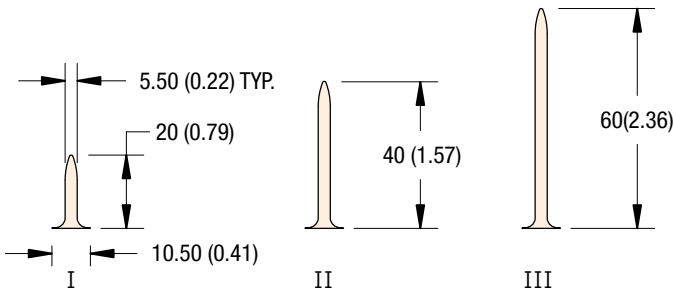

W = Conveyor Belt Width
 A = Pocket Width
 $A = W - 116 \text{ mm (4.57 in)}$

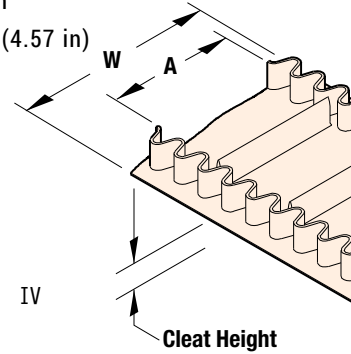

Specialty Cleated Belt Selection Guide

Part No.	Base Belt	Belt Thickness, mm (in)	Belt Surface Material	Cleat Height, mm (in)	Cleat Material	Maximum Part Temp. °C (°F)	FDA Approved	Chemical Resistance	Moisture Resistance	Illustration	
Cleated	N	Sealed Edge	1.5 (0.06)	Urethane	20 (0.79)	Urethane	80 (176)	Yes	Good	Good	I
	P	Sealed Edge	1.5 (0.06)	Urethane	40 (1.57)	Urethane	80 (176)	Yes	Good	Good	II
	Q	Sealed Edge	1.5 (0.06)	Urethane	60 (2.36)	Urethane	80 (176)	Yes	Good	Good	III
	R	Encased	2.0 (0.08)	Urethane	0.79 (20)	Urethane	100 (212)	Yes	Good	Very Good	I
	S	Encased	2.0 (0.08)	Urethane	40 (1.57)	Urethane	100 (212)	Yes	Good	Very Good	II
	T	Encased	2.0 (0.08)	Urethane	60 (2.36)	Urethane	100 (212)	Yes	Good	Very Good	III
Sidewall Cleated	U	Standard	1.5 (0.06)	Urethane	30 (1.18)	Urethane	80 (176)	Yes	Good	Poor	IV
	V	Standard	1.5 (0.06)	Urethane	50 (1.97)	Urethane	80 (176)	Yes	Good	Poor	IV
	W	Sealed Edge	1.5 (0.06)	Urethane	30 (1.18)	Urethane	80 (176)	Yes	Good	Good	IV
	X	Sealed Edge	1.5 (0.06)	Urethane	50 (1.97)	Urethane	80 (176)	Yes	Good	Good	IV
	Y	Encased	1.5 (0.06)	Urethane	30 (1.18)	Urethane	80 (176)	Yes	Good	Very Good	IV
	Z	Encased	1.5 (0.06)	Urethane	50 (1.97)	Urethane	80 (176)	Yes	Good	Very Good	IV

SPECIALTY CLEATED BELT SPACING

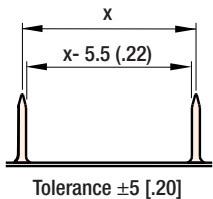

- Cleat spacing is determined by conveyor length and desired number of cleats
- Minimum spacing = 50 mm (2 in)
- Spacing accuracy = ±5 mm (.20 in)
- Maximum 2135 mm (84 in) conveyor length for 487 mm (18 in) and wider conveyors
- Maximum 508 mm (20 in) cleat spacing for 2135 mm (84 in) and longer conveyors

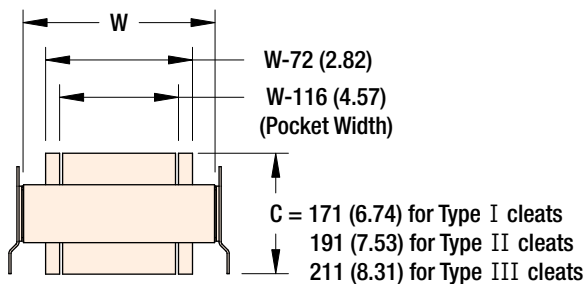

Sidewall Belting

Dim = mm (in)

POSITIVE DRIVE BELTING

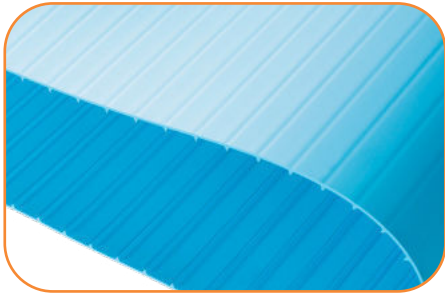

Specifications

- Solid Urethane material
- Drive lugs on 25 mm (1 in) spacing
- Available in Blue or White
- Excellent abrasion and tear resistance

(Also available in white)

Positive Drive Belt Selection Guide							
Description	Surface Material	Belt Thickness, mm (in)	Maximum Part Temp. C (F)	Sanitation Temperature °C (°F)	USDA Approval	Chemical Resistance	Special Characteristics
Flat Belt Smooth, Matte Finish	Homogeneous Thermoplastic, FDA Compliant Polyurethane 01 Smooth top white 02 Smooth top blue	6 mm (0.236 in)	-28 to 80 (-20 to 176)	up to 85 (185)	x	Very Good	Smooth Surface



TIP-UP TAILS*

FOR ACCESS INSIDE CONVEYOR FOR CLEANING AND MAINTENANCE (STRAIGHTS ONLY)

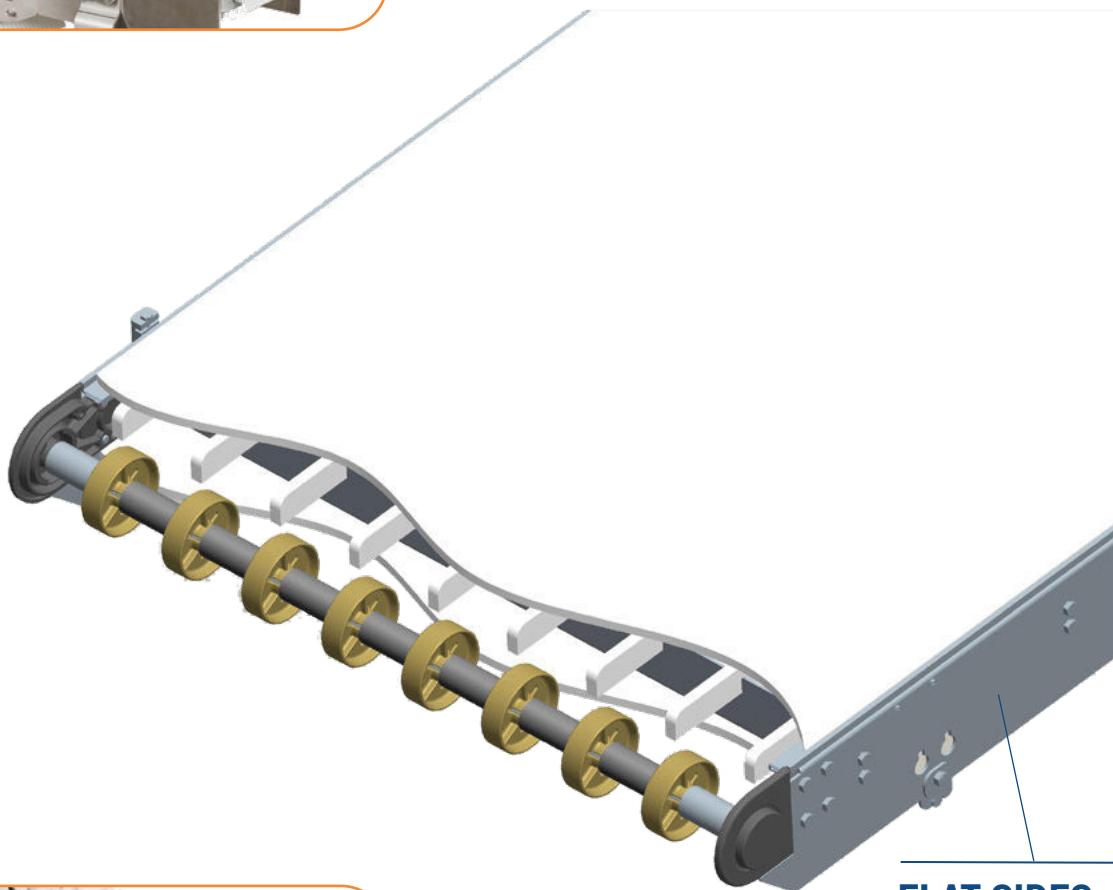

INNOVATIVE CURVE CHAIN

WITH CENTER BEARING TO ELIMINATE FRICTION, ALLOWING 4 CURVES ON A SINGLE MOTOR

SAFEST CURVE CHAIN IN THE INDUSTRY

CHAIN OPENINGS LESS THAN 4 MM, EVEN IN THE CURVES

FLAT SIDES

ALLOW FOR FLEXIBILITY WHEN MOUNTING ACCESSORIES, INTERFACING WITH OTHER EQUIPMENT OR TRANSFERRING PRODUCTS



*Note: Do not run the conveyor with the tail in the tip-up position.



COMPACT CURVE FOOTPRINT
WITH INFEED AND OUTFEED SECTIONS
AS SHORT AS 457 MM (18 IN)

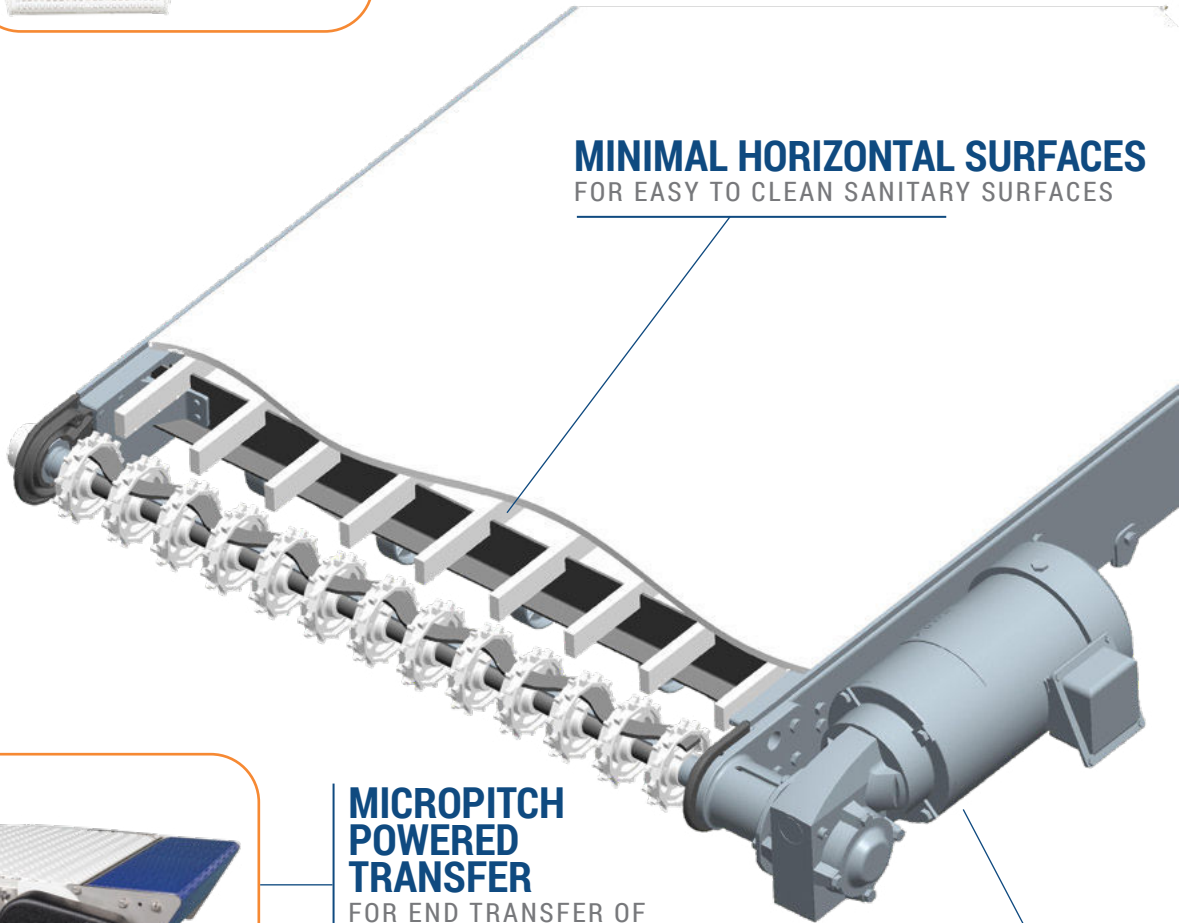

MINIMAL HORIZONTAL SURFACES
FOR EASY TO CLEAN SANITARY SURFACES

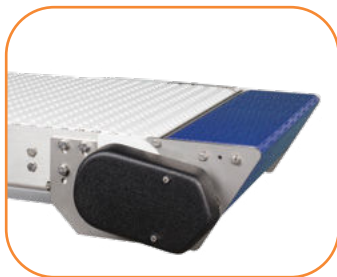

**MICROPITCH
POWERED
TRANSFER**
FOR END TRANSFER OF
PRODUCT AS SMALL AS
75 MM (3 IN) LONG

**SIDE & BOTTOM
MOUNT MOTOR
PACKAGE**
FOR APPLICATION
FLEXIBILITY



**ROBUST OPEN LEG
SUPPORT STANDS**
7 GAUGE WELDED
STAINLESS STEEL

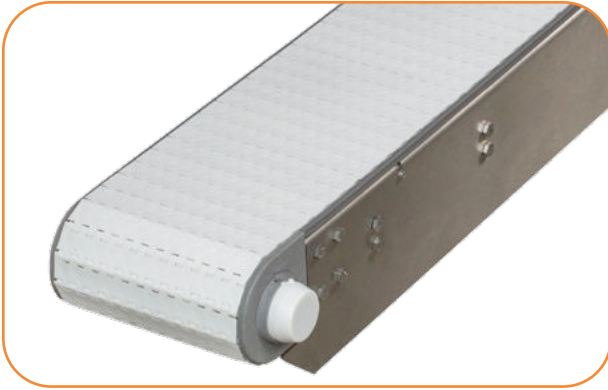

Specifications

- Loads up to 341 kg (750 lbs) or 98 kg/sq m (20 lbs/sq ft)*
- Belt speeds up to 78.6 m/min (260 ft/min)
- Belt widths: 203 mm (8 in) to 914 mm (36 in)
- Conveyor lengths: 915 mm (36 in) to 25,000 mm (82 ft)
- Bolt-together 304 Stainless Steel Frame
- Hard chrome coated bearing with FDA H1 food grade grease
- FDA approved belting and plastic components
- Open design with minimal horizontal surfaces
- Suitable for use in wet environments
- Stainless Steel construction for wipe down and low pressure washdown with non-caustic solutions



OPTIONAL: Nose Bar Idler Tail
25 mm (1 in) diameter for small parts transfer. Speeds up to 79 m/min (260 ft/min)



OPTIONAL: Nosebar Drive Tail
25 mm (1 in) diameter for small parts transfer. Speeds up to 79 m/min (260 ft/min)

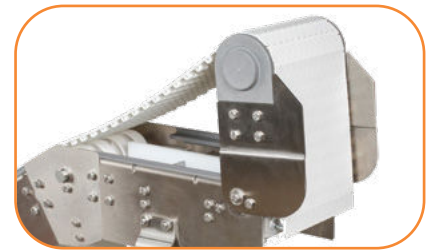

OPTIONAL: Tip-Up Tail**

AquaGard 7350 Modular Flat Belt End Drive Conveyor

73 B M W W W - L L L L L D I A S S P P P P B B - X T¹ T² T³ T⁴

— Conveyor Tail Options X (if required) *See Drive Shaft Position Chart on next page
 O = No shaft (3 and 4 always 0 for tip-up tail), K = Keyed Shaft, P = Power transfer Keyed shaft

— Belt Type: Chain See Pages 42-43 for belt selection

— Profile (D side)

— Profile (A side)
 01 = Low Side 04 = 75 mm (3 in) High Side 05 = 25 mm (1 in) High Side 06 = 152 mm (6 in) High Side
 13 = Fully Adjustable Round 14 = Tool-less Fully Adjustable Round 17 = Fully Adjustable 32 mm (1.25 in) Flat
 18 = Tool-less Fully Adjustable 25 mm (1 in) Flat

— Idler Stand Location: Note: Tip-up tail start at 18"
 A = No Stand Mount Mounting brackets C = 457 mm (18 in) from end D = 610 mm (24 in) from end E = 762 mm (30 in) from end
 F = 914 mm (36 in) from end H = 457 mm (18 in) from end with braces J = 610 mm (24 in) from end with braces
 K = 762 mm (30 in) from end with braces M = 914 mm (36 in) from end with braces

— Drive Stand Location:
 A = No Stand Mount Mounting brackets B = 305 mm (12 in) from end C = 457 mm (18 in) from end D = 610 mm (24 in) from end
 G = 305 mm (12 in) from end with braces H = 457 mm (18 in) from end with braces J = 610 mm (24 in) from end with braces

— Drive Shaft Position: A or D

— Idler Tail Type: 1 = Standard, 2 = Nose Bar, 3 = Tip-up Standard, 4 = Tip-up Nose bar

— Drive Tail Types: 1 = Standard Bottom/Side, 5 = Nose bar

— Conveyor Length (mm): 00915 to 25000 in 5 mm increments (36 – 984 in)

— Conveyor Width Reference (mm): = 203 to 914 (8 – 36 in)

— Documentation Language: M = US English, U = Europe English, D = German, F = French, S = Spanish

* Conveyor load capacity depends on conveyor size, incline, motor position, accumulated loads and other factors.

** Note: Do not run the conveyor with the tail in the tip-up position.

Order gearmotor mounting packages and gearmotors separately, see pages 44-48.
 For support stands and accessories, see page 50-55.

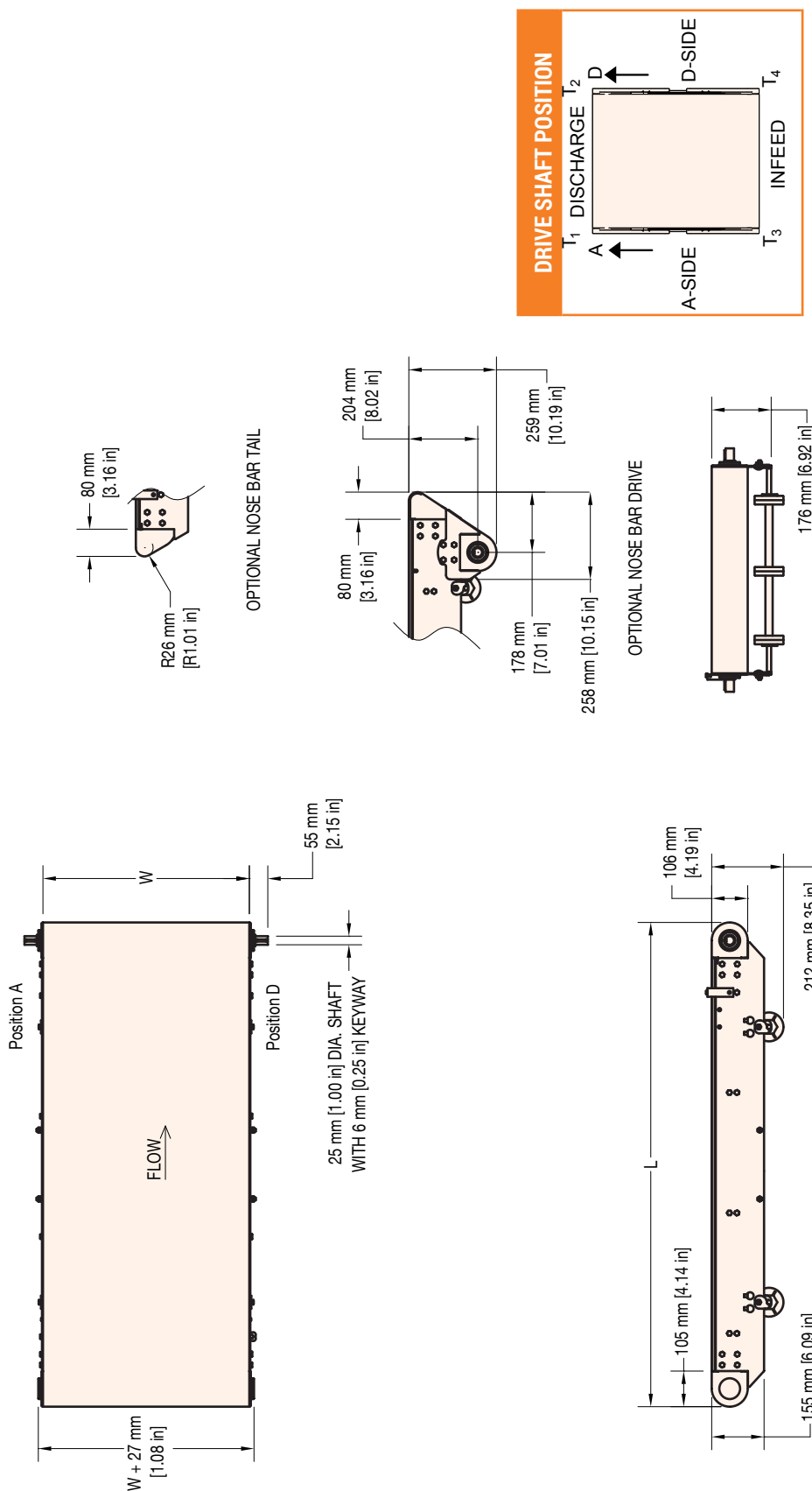

W = Conveyor Belt Width Dim = mm (in)

STANDARD SIZES															
Conveyor Width Reference	203	254	305	356	406	457	508	559	610	660	711	762	813	864	914
Conveyor Belt Width (W)	203 (8)	254 (10)	305 (12)	356 (14)	406 (16)	457 (18)	508 (20)	559 (22)	610 (24)	660 (26)	711 (28)	762 (30)	813 (32)	864 (34)	914 (36)
Conveyor Length Reference	00915														
Conveyor Length (L)	0915 (36)														
	00005 increments up to...														
	00005 (0.2) increments up to...														
	25000 (984)														

Due to the wide variety of drive set ups and applications, point of installation guarding is the responsibility of the end user.

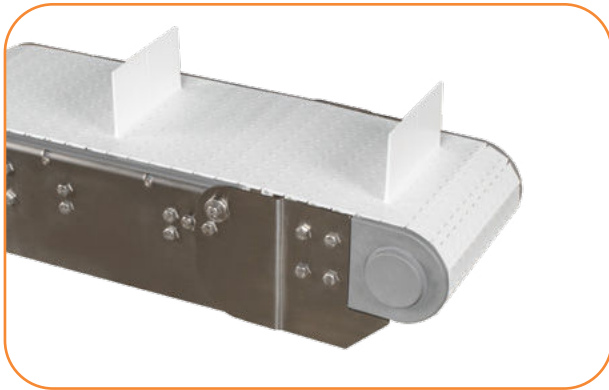

Specifications

- Loads up to 341 kg (750 lbs) or 98 kg/sq m (20 lbs/sq ft)*
- Belt speeds up to 78.6 m/min (260 ft/min)
- Belt widths: 203 mm (8 in) to 610 mm (24 in)
- Conveyor lengths: 915 mm (36 in) to 25,000 mm (82 ft)
- Cleat heights from 25 mm (1 in) to 75 mm (3 in)
- Bolt-together 304 Stainless Steel Frame
- Hard chrome coated bearing with FDA H1 food grade grease
- FDA approved belting and plastic components
- Open design with minimal horizontal surfaces
- Suitable for use in wet environments
- Stainless Steel construction for wipe down and low pressure washdown with non-caustic solutions

Features optional tip-up tail



**OPTIONAL:
High Side Guides**
Up to 152 mm (6 in) tall

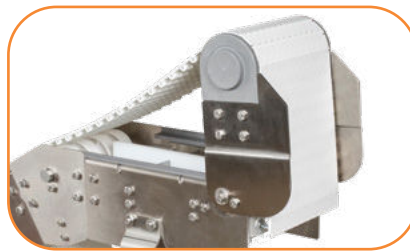

**OPTIONAL:
Tip-Up Tail****

AquaGard 7350 Modular Cleated Belt End Drive Conveyor

73 F M W W W - L L L L L D T A S S P B B S S - X T¹ T² T³ T⁴

— Conveyor Tail Options X (if required)
O = No shaft (3 and 4 always 0 for tip-up tail), K = Keyed Shaft

— Cleat Spacing: 01 - 99 (links)

— Belt Type: Chain See Pages 42-43 for belt selection

— Profile (A side)
01 = Low Side 02 = Cleated 25mm (1 in) Bolt On High Side
03 = Cleated 75mm (3 in) Bolt On High Side 06 = Cleated 152mm (6 in) Bolt on High Side

— Idler Stand Location: Note: Tip-up tail start at 18°
A = No Stand Mount Mounting brackets C = 457 mm (18 in) from end D = 610 mm (24 in) from end E = 762 mm (30 in) from end
F = 914 mm (36 in) from end H = 457 mm (18 in) from end with braces J = 610 mm (24 in) from end with braces
K = 762 mm (30 in) from end with braces M = 914 mm (36 in) from end with braces

— Drive Stand Location:
A = No Stand Mount Mounting brackets B = 305 mm (12 in) from end C = 457 mm (18 in) from end D = 610 mm (24 in) from end
G = 305 mm (12 in) from end with braces H = 457 mm (18 in) from end with braces J = 610 mm (24 in) from end with braces

— Drive Shaft Position: A or D

— Idler Tail Type: 1 = Standard, 3 = Tip-up Standard

— Drive Tail Types: 1 = Standard Bottom/Side,

— Conveyor Length (mm): 00915 to 25000 in 5 mm increments (36 - 984 in)

— Conveyor Width Reference (mm): = 203 to 610 (8 - 34 in)

— Documentation Language: M = US English, U = Europe English, D = German, F = French, S = Spanish

* Conveyor load capacity depends on conveyor size, incline, motor position, accumulated loads and other factors.

** Note: Do not run the conveyor with the tail in the tip-up position.

Order gearmotor mounting packages and gearmotors separately, see pages 44-48.
For support stands and accessories, see page 50-55.

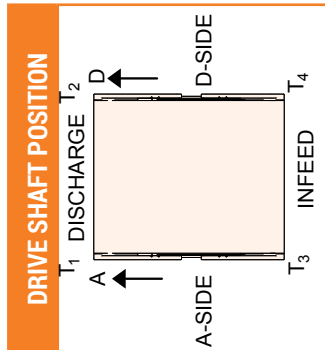
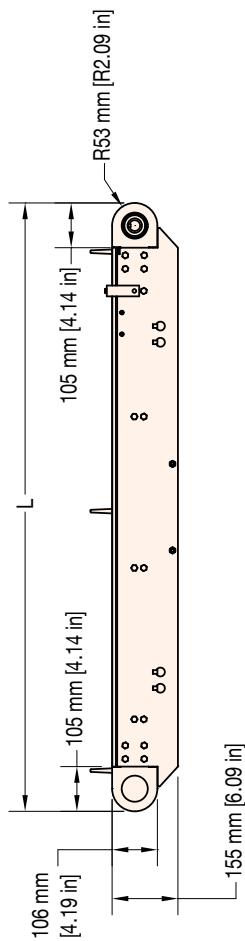
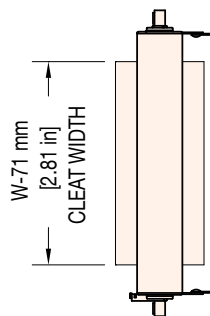
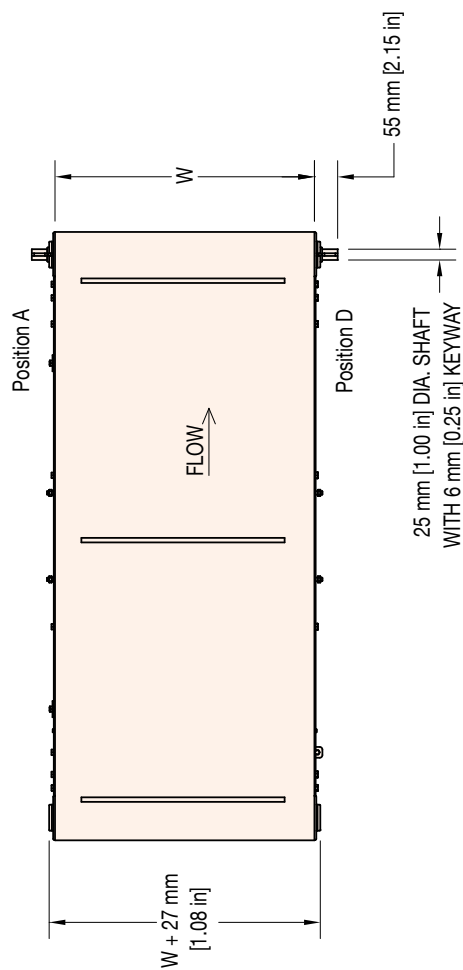

W = Conveyor Belt Width Dim = mm (in)

STANDARD SIZES									
Conveyor Width Reference	203	254	305	356	406	457	508	559	610
Conveyor Belt Width (W)	203	254	305	356	406	457	508	559	610
	(8)	(10)	(12)	(14)	(16)	(18)	(20)	(22)	(24)
Conveyor Length Reference	00915		00005 increments up to...		00005 increments up to...		25000		
Conveyor Length (L)	0915 (36)		00005 (0.2) increments up to...		00005 (0.2) increments up to...		25000 (984)		

Due to the wide variety of drive set ups and applications, point of installation guarding is the responsibility of the end user.



Specifications

- Loads up to 227 kg (500 lbs) or 98 kg/sq m (20 lbs/sq ft)*
- Belt speeds up to 78.6 m/min (260 ft/min)
- Belt widths: 152 mm (6 in) to 610 mm (24 in)
- Conveyor section lengths: 460 mm (18 in) to 15240 mm (600 in)
- Curve angles of 45, 90, 135 and 180 degrees
- Bolt-together Stainless Steel Frame
- Mold to width chain up to 457 mm (18 in) wide
- No chain opening exceeding 4 mm (0.15 in)
- FDA approved belting and plastic components
- Chain supported with stainless steel center bearing, increasing load capacity and the ability to have up to 4 curves on a single motor
- Optional powered transfer for smooth transfer of parts as short as 75 mm (3 in) in diameter
- Suitable for use in wet environments
- Stainless Steel construction for wipe down and low pressure washdown with non-caustic solutions



Curve Innovation

Integrated chain bearing and guide rail eliminates friction

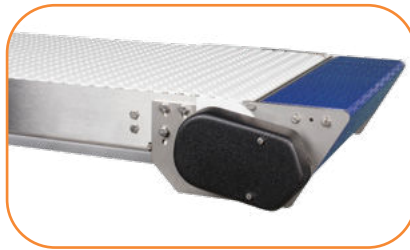

OPTIONAL: Powered Transfer

For small parts and maintaining speeds through transfer. Series driven with speeds up to 78.6 m/min (260 ft/min). Transfer parts as short as 75 mm (3 in) long.



**STANDARD FEATURE:
Flush Top, Low Side Frame**

Multiple Curve Configurations

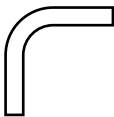

Single Curve



S-Curve

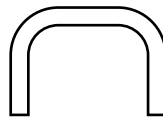

U-Curve

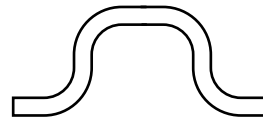

Up to 4 Curves

* Conveyor load capacity depends on conveyor size, incline, motor position, accumulated loads and other factors.

Order gearmotor mounting packages and gearmotors separately, see pages 44-48.
For support stands and accessories, see page 50-55.

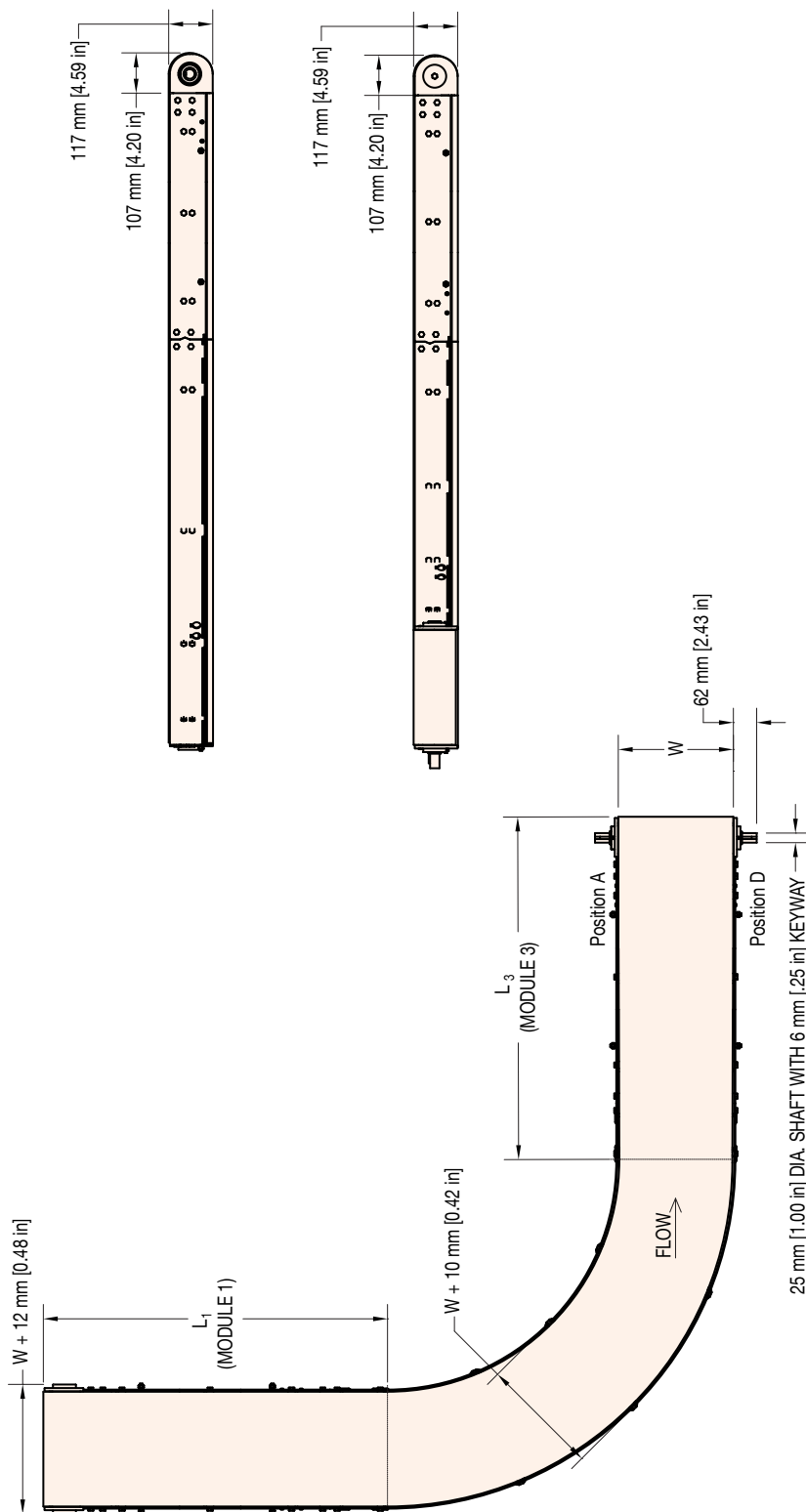

W = Conveyor Belt Width Dim = mm (in)

STANDARD SIZES				
Conveyor Width Reference	152	305	457	610
Conveyor Belt Width (W)	152	305	457	610
	(6)	(12)	(18)	(24)
Conveyor Length Reference	00460	00005 increments up to...		15240
Conveyor Length (L)	00460 (18)	00005 (0.2) increments up to...		15240 (600)

NOTE: Total length of all sections cannot exceed 25,000 mm (82 ft)
Maximum of 4 curves

Belt Width Table	
Conveyor Width mm (in)	Inside Radius of Belt
152 (6)	304 (12)
305 (12)	610 (24)
457 (18)	914 (36)
610 (24)	1220 (48)

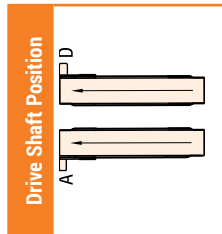

Due to the wide variety of drive set ups and applications, point of installation guarding is the responsibility of the end user.

AquaGard 7350 Series Curved Modular Belt Conveyor - Infeed Module

73 T 1 M W W W - L L L L L I S P P P P B B - S S

— Sequence 01
 — Belt Type: Chain (XA = Plain Chain, XB = Friction Insert)
 — Profile (D side)
 — Profile (A side)
 01 = Low Side 04 = 75 mm (3 in) High Side 05 = 25 mm (1 in) High Side 06 = 152 mm (6 in) High Side
 13 = Fully Adjustable Round 14 = Tool-less Fully Adjustable Round 17 = Fully Adjustable 32 mm (1.25 in) Flat
 18 = Tool-less Fully Adjustable 25 mm (1 in) Flat
 — Idler Stand Location:
 A = No Stand Mount Mounting brackets C = 457 mm (18 in) from end D = 610 mm (24 in) from end E = 762 mm (30 in) from end
 F = 914 mm (36 in) from end G = 305 mm (12 in) from end with braces H = 457 mm (18 in) from end with braces
 J = 610 mm (24 in) from end with braces K = 762 mm (30 in) from end with braces M = 914 mm (36 in) from end with braces
 — Idler Tail Type: N = Standard Idler, T = Power Transfer D side, P = Power Transfer A side A = Output Shaft A side, D = Output Shaft D side
 — Conveyor Length (mm): 00460 to 15240 in 5 mm increments
 — Conveyor Width Reference (mm): = 152, 305, 457 or 610 (6, 12, 18 or 24 in)
 — Documentation Language: M = US English, U = Europe English, D = German, F = French, S = Spanish
 — Module Type: 1 = Infeed Module
 — Conveyor Type: T = Modular Belt Curve

AquaGard 7350 Series Curved Modular Belt Conveyor - Curve Module

73 T 2 M W W W - A A A D P P P P B B - S S

— Sequence 01
 — Belt Type: Chain (XA = Plain Chain, XB = Friction Insert)
 — Profile (D side)
 — Profile (A side)
 01 = Low Side 04 = 75 mm (3 in) High Side 05 = 25 mm (1 in) High Side 06 = 152 mm (6 in) High Side
 13 = Fully Adjustable Round 14 = Tool-less Fully Adjustable Round 17 = Fully Adjustable 32 mm (1.25 in) Flat
 18 = Tool-less Fully Adjustable 25 mm (1 in) Flat
 — Direction: L = Left Hand Turn R = Right Hand Turn
 — Degrees of Turn: = 045, 090, 135 or 180
 — Conveyor Width Reference (mm): = 152, 305, 457 or 610 (6, 12, 18 or 24 in)
 — Documentation Language: M = US English, U = Europe English, D = German, F = French, S = Spanish
 — Module Type: 2 = Curve Module
 — Conveyor Type: T = Modular Belt Curve

AquaGard 7350 Series Curved Modular Belt Conveyor - Intermediate Module

73 T 3 M W W W - L L L L L B P P P P B B - S S

— Sequence 01
 — Belt Type: Chain (XA = Plain Chain, XB = Friction Insert)
 — Profile (D side)
 — Profile (A side)
 01 = Low Side 04 = 75 mm (3 in) High Side 05 = 25 mm (1 in) High Side 06 = 152 mm (6 in) High Side
 13 = Fully Adjustable Round 14 = Tool-less Fully Adjustable Round 17 = Fully Adjustable 32 mm (1.25 in) Flat
 18 = Tool-less Fully Adjustable 25 mm (1 in) Flat
 — Stand Style: A = No Braces, B = Braces
 — Conveyor Length (mm): 00610 to 15240 in 5 mm increments
 — Conveyor Width Reference (mm): = 152, 305, 457 or 610 (6, 12, 18 or 24 in)
 — Documentation Language: M = US English, U = Europe English, D = German, F = French, S = Spanish
 — Module Type: 3 = Intermediate Module
 — Conveyor Type: T = Modular Belt Curve

AquaGard 7350 Series Curved Modular Belt Conveyor - Drive Modular

73 T 5 M W W W - L L L L L D A S P P P P B B - S S

— Sequence 01
 — Belt Type: Chain (XA = Plain Chain, XB = Friction Insert)
 — Profile (D side)
 — Profile (A side)
 01 = Low Side 04 = 75 mm (3 in) High Side 05 = 25 mm (1 in) High Side 06 = 152 mm (6 in) High Side
 13 = Fully Adjustable Round 14 = Tool-less Fully Adjustable Round 17 = Fully Adjustable 32 mm (1.25 in) Flat
 18 = Tool-less Fully Adjustable 25 mm (1 in) Flat
 — Drive Stand Location:
 A = No Stand Mount Mounting brackets B = 305mm (12 in) from end C = 457 mm (18 in) from end D = 610 mm (24 in) from end
 G = 305 mm (12 in) from end with braces H = 457 mm (18 in) from end with braces J = 610 mm (24 in) from end with braces
 — Drive Position: A or D
 — Drive Tail Type: N = Standard Idler, P = Powered Transfer D = Double Output Shaft
 — Conveyor Length (mm): 00460 to 15240 in 5 mm increments
 — Conveyor Width Reference (mm): = 152, 305, 457 or 610 (6, 12, 18 or 24 in)
 — Documentation Language: M = US English, U = Europe English, D = German, F = French, S = Spanish
 — Module Type: 5 = Drive Module
 — Conveyor Type: T = Modular Belt Curve



Powered Transfer

- 13 mm (5 in) diameter roller for small part transfers
- Maintains speed through the transfer
- 8 mm micropitch chain series driven off of tail module
- Conveyor widths 152 mm (6 in) to 914 mm (36 in)
- Belt speeds up to 53 m/min (175 f/min)
- Available as an option on Modular Belt Curve
- Can be located on drive and/or idler tail

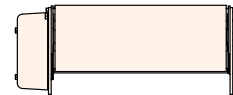
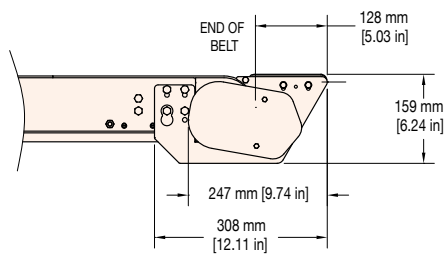
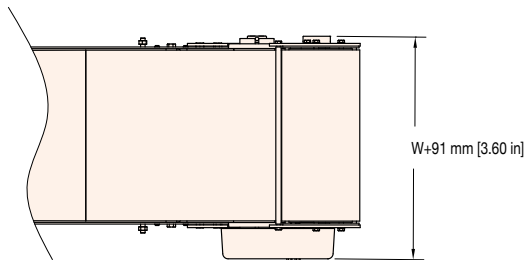



Specifications

- Loads up to 45 kg (100 lbs) or 98 kg/sq m (20 lbs/sq ft)*
- Belt speeds up to 78.6 m/min (260 ft/min)
- Belt widths: 203 mm (8 in) to 610 mm (24 in)
- Conveyor section lengths: 610 mm (24 in) to 6100 mm (240 in)
- Maximum total conveyor length of 12190 mm (480 in)
- Angles from 5 degrees to 30 degrees in 5 degree increments
- Bolt-together Stainless Steel Frame
- FDA approved belting and plastic components
- Suitable for use in wet environments
- Stainless Steel construction for wipe down and low pressure washdown with non-caustic solutions

Configurations

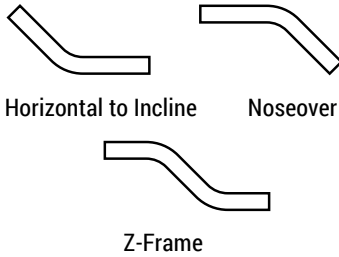

OPTIONAL:
Friction Insert Belts



OPTIONAL:
Tip-Up Tail**

AquaGard 7350 Modular Z-Frame Flat Belt Conveyor

73	B	M	WWW	-	LLLL	-	LLLL	-	LLLL	A	A	E	D	I	A	S	S	P	P	B	B	-	X	T ¹	T ²	T ³	T ⁴
																							Conveyor Tail Options X (if required) *See Drive Shaft Position Chart on next page O = No shaft (3 and 4 always 0 for tip-up tail), K = Keyed Shaft, P = Power Transfer Keyed Shaft				
																							Belt Type: Chain (use chain from 7400 Series)				
																							Profile: 01 = Low Side 04 = 75 mm (3 in) High Side 05 = 25 mm (1 in) High Side 06 = 152mm (6 in) high side 13 = Fully Adjustable Round 14 = Tool-less Fully Adjustable Round 17 = Fully Adjustable 32 mm (1.25 in) Flat 18 = Tool-less Fully Adjustable 25 mm (1 in) Flat				
																							Idle Stand Location: Note: Tip-up tail start at 18" A = No Stand Mount Mounting brackets C = 457 mm (18 in) from end D = 610 mm (24 in) from end E = 762 mm (30 in) from end F = 914 mm (36 in) from end H = 457 mm (18 in) from end with braces J = 610 mm (24 in) from end with braces K = 762 mm (30 in) from end with braces M = 914 mm (36 in) from end with braces				
																							Drive Stand Location: A = No Stand Mount Mounting brackets B = 305 mm (12 in) from end C = 457 mm (18 in) from end D = 610 mm (24 in) from end G = 305 mm (12 in) from end with braces H = 457 mm (18 in) from end with braces J = 610 mm (24 in) from end with braces				
																							Drive Shaft Position: A or D				
																							Idle Tail Type: 1 = Standard, 3 = Tip-up Standard				
																							Drive Tail Type: 1 = Standard Bottom/Side				
																							Belt Direction: E = Inclining, D = Declining				
																							Angle: 05 degrees thru 30 degrees in 05 degree increments				
																							Conveyor L3 Lower Horizontal Section Length (mm): 0610 to 6100 (24 - 240 in)				
																							Conveyor L2 Angled Section Length (mm): 0610 to 6100 (24 - 240 in)				
																							Conveyor L1 Upper Horizontal Section Length (mm): 0610 to 6100 (24 - 240 in)				
																							Conveyor Width Reference (mm): = 203 to 610 (8 - 24 in)				
																							Documentation Language: M = US English, U = Europe English, D = German, F = French, S = Spanish				

* Conveyor load capacity depends on conveyor size, incline, motor position, accumulated loads and other factors.

** Note: Do not run the conveyor with the tail in the tip-up position.

Order gearmotor mounting packages and gearmotors separately, see pages 44-48.
For support stands and accessories, see page 50-55.

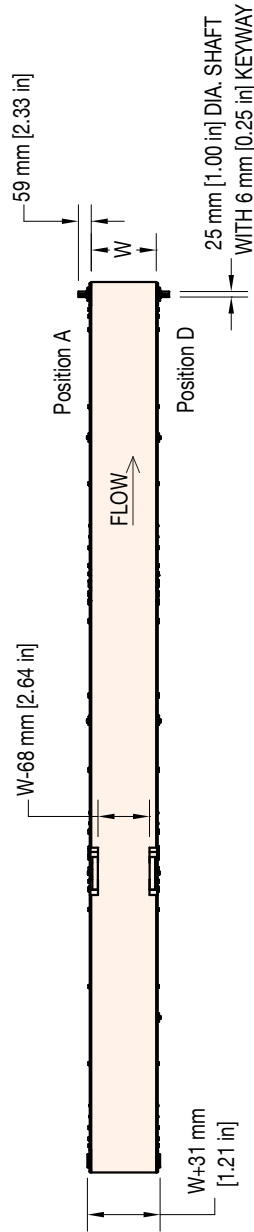

25 mm [1.00 in] DIA. SHAFT
WITH 6 mm [0.25 in] KEYWAY

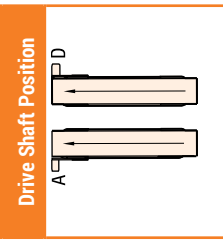
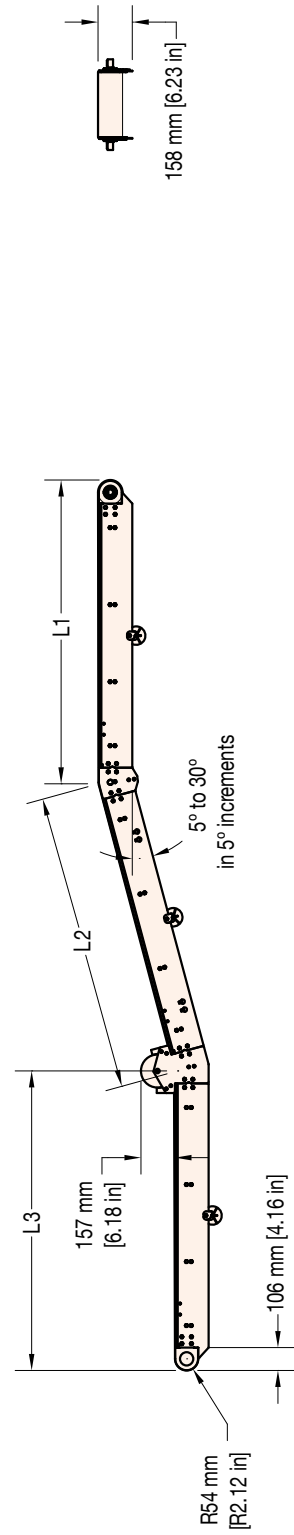

W = Conveyor Belt Width Dim = mm (in)

STANDARD SIZES										
Conveyor Width Reference	152	203	254	305	356	406	457	508	559	610
Conveyor Belt Width (W)	152	203	254	305	356	406	457	508	559	610
	(6)	(8)	(10)	(12)	(14)	(16)	(18)	(20)	(22)	(24)
Conveyor Length Reference	0610		00005 increments up to...							
Conveyor Length (L1/L2/L3)	0610 (24)	00005 (0.2) increments up to...								6100 (240)

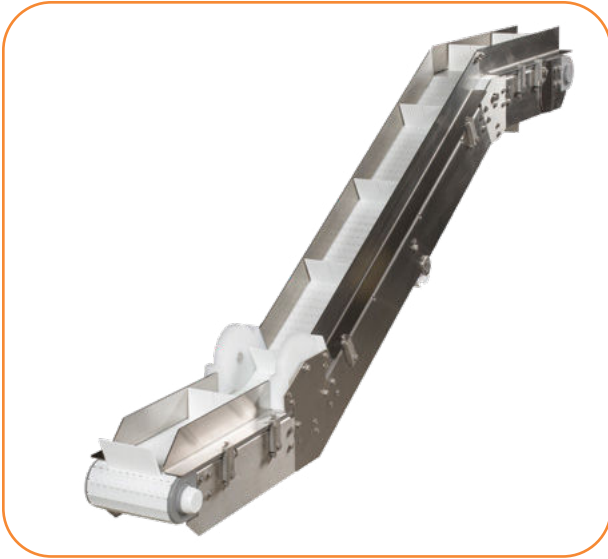

Specifications

- Loads up to 45 kg (100 lbs) or 98 kg/sq m (20 lbs/sq ft)*
- Belt speeds up to 78.6 m/min (260 ft/min)
- Belt widths: 152 mm (6 in) to 610 mm (24 in)
- Conveyor section lengths: 610 mm (24 in) to 6100 mm (240 in)
- Maximum total conveyor length of 25,000 mm (82 ft)
- Angles from 30 degrees to 60 degrees in 5 degree increments
- Bolt-together Stainless Steel Frame
- FDA approved belting and plastic components
- Suitable for use in wet environments
- Stainless Steel construction for wipe down and low pressure washdown with non-caustic solutions

Configurations

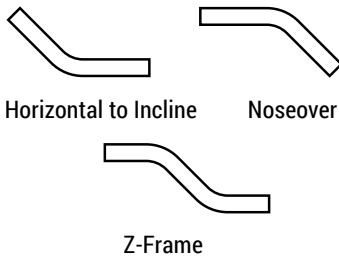

**OPTIONAL:
High Side Guides**
Up to 152 mm (6 in) tall

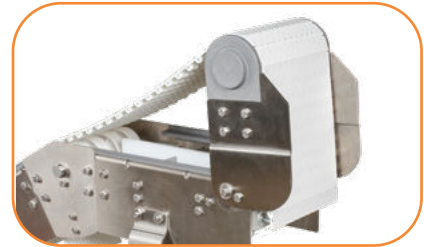

**OPTIONAL:
Tip-Up Tail****

AquaGard 7350 Z-Frame Modular Cleated Conveyor

73 F M W W W - L L L L - L L L L - L L L L A A E D I A S S P B B S S - X T¹ T² T³ T⁴

- Conveyor Tail Options X (if required) *See Drive Shaft Position Chart on next page
0 = No shaft (3 and 4 always 0 for tip-up tail), K = Keyed Auxiliary Shaft

- Spacing: 01 - 99 (links)

- Belt/Cleat Type: Chain See Pages 42-43 for belt selection

- Profile: 0 = Low Side 2 = Cleated 25mm (1 in) Bolt On High Side
3 = Cleated 75mm (3 in) Bolt On High Side 6 = Cleated 152mm (6 in) Bolt on High Side

- Idler Stand Location: Note: Tip-up tail start at 18"

A = No Stand Mount Mounting brackets C = 457 mm (18 in) from end D = 610 mm (24 in) from end
E = 762 mm (30 in) from end F = 914 mm (36 in) from end H = 457 mm (18 in) from end with braces
J = 610 mm (24 in) from end with braces K = 762 mm (30 in) from end with braces
M = 914 mm (36 in) from end with braces

- Drive Stand Location:

A = No Stand Mount Mounting brackets B = 305 mm (12 in) from end C = 457 mm (18 in) from end
D = 610 mm (24 in) from end G = 305 mm (12 in) from end with braces H = 457 mm (18 in) from end with braces
J = 610 mm (24 in) from end with braces

- Drive Shaft Position: A or D

- Idler Tail Type: 1 = Standard, 3 = Tip-up Standard

- Drive Tail Type: 1 = Standard Bottom/Side

- Belt Direction: E = Inclining, D = Declining

- Angle: 30 degrees thru 60 degrees in 05 degree increments

- Conveyor L3 Lower Horizontal Section Length (mm): 0610 to 6100 (64 - 240 in)

- Conveyor L2 Angled Section Length (mm): 0610 to 6100 (24 - 240 in)

- Conveyor L1 Upper Horizontal Section Length (mm): 0610 to 6100 (24 - 240 in)

- Conveyor Width Reference (mm): = 152 to 610 (6 - 24 in)

- Documentation Language: M = US English, U = Europe English, D = German, F = French, S = Spanish

* Conveyor load capacity depends on conveyor size, incline, motor position, accumulated loads and other factors.

** Note: Do not run the conveyor with the tail in the tip-up position.

Order gearmotor mounting packages and gearmotors separately, see pages 44-48.
For support stands and accessories, see page 50-55.

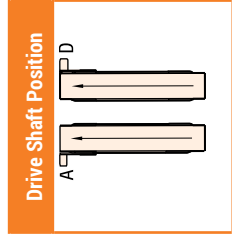
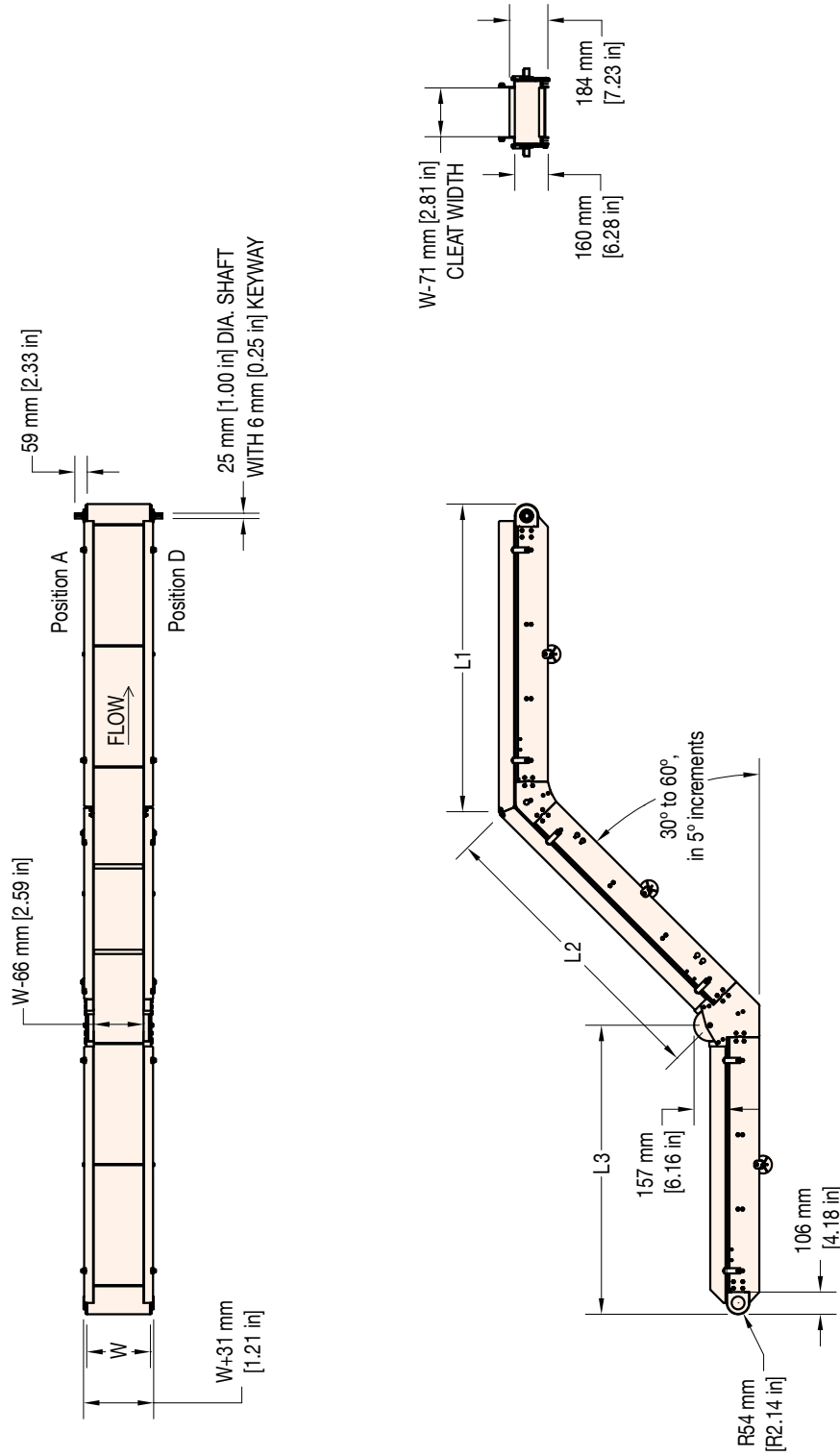

W = Conveyor Belt Width Dim = mm (in)

STANDARD SIZES										
Conveyor Width Reference	152	203	254	305	356	406	457	508	559	610
Conveyor Belt Width (W)	152	203	254	305	356	406	457	508	559	610
	(6)	(8)	(10)	(12)	(14)	(16)	(18)	(20)	(22)	(24)
Conveyor Length Reference	0610		00005 increments up to...							
Conveyor Length (L1/L2/L3)	0610 (24)	00005 (0.2) increments up to...								6100 (240)

MODULAR BELT PROFILES

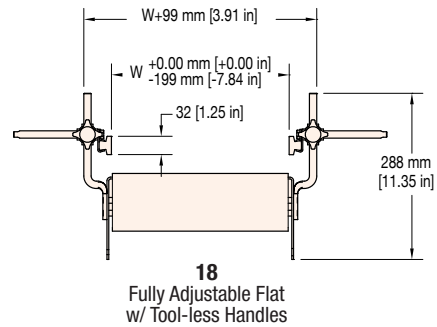
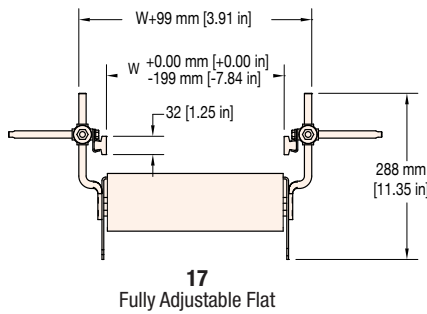
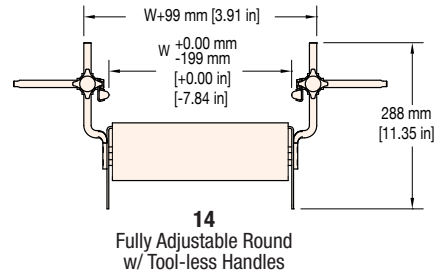
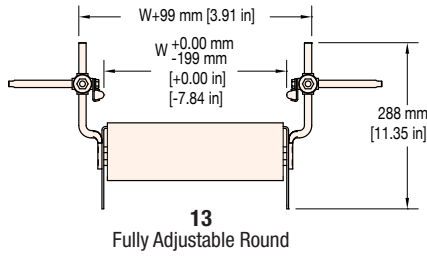
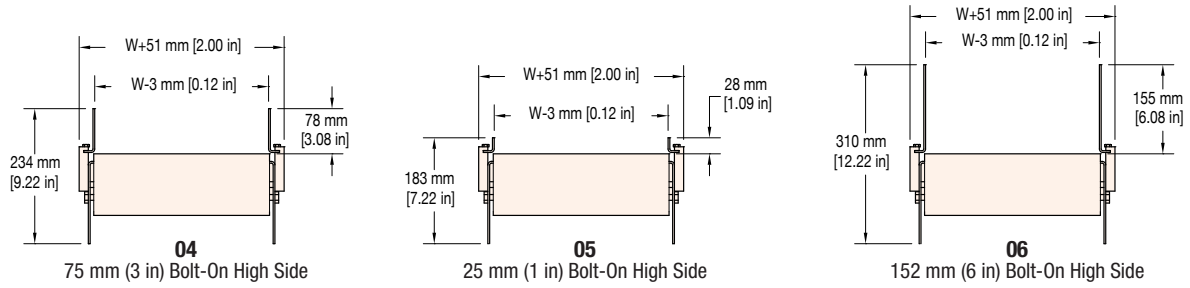

W = Conveyor Belt Width **Dim** = mm (in)

Due to the wide variety of drive set ups and applications, point of installation guarding is the responsibility of the end user.

CLEATED MODULAR BELT PROFILES

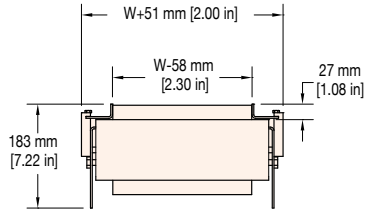

02
25 mm (1 in) Bolt-On High Side

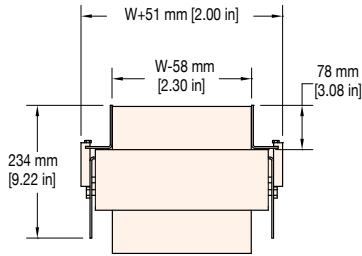

03
75 mm (3 in) Bolt-On High Side

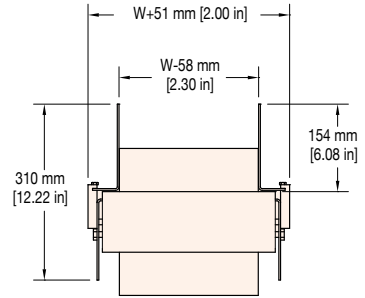

06
152mm (6 in) Bolt-On High Side

W = Conveyor Belt Width Dim = mm (in)

Due to the wide variety of drive set ups and applications, point of installation guarding is the responsibility of the end user.

MODULAR BELT TYPES



Flat Top Belts

provide a closed surface for complete product support, easy wiping.

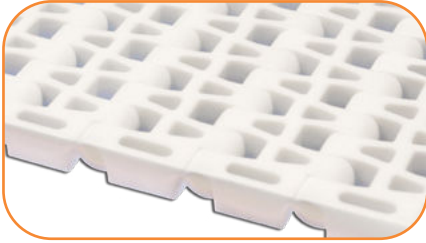

Flush Grid Belts

provide an open surface for better drainage, cleaning or air flow/cooling.



Friction Inserts

are available for incline applications. Inserts may be placed along entire length of the belt or spaced on 51 mm (2 in), 102 mm (4 in), 152 mm (6 in) or 305 mm (12 in) centers. Friction inserts are indented 51 mm (2 in) from each belt edge.



Curve Belts

provide a tight radius, space saving corner. Side tabs ensure positive belt tracking with a flush top design. Stainless bearings reduce friction providing capability of up to (4) corners.



Cleated Belts

provide a sturdy cleat for elevation at steep inclines. Cleats available in 25 mm (1 in) and 76 mm (3 in) heights.

Modular Belt Selection Guide

Belt Type		Part Number Reference	Description mm (in)	% Open	Pitch mm (in)	Belt Thickness mm (in)	Color	Belt Material	Rod Material	Minimum Product Temperature C (F)	Maximum Product Temperature C (F)**	FDA / CFIA Approved*	Chemical Resistance	Wear Resistance	Maximum Incline / Decline (degrees)**	Nose Bar Idler Diameter mm (in)
Straight Flat Belts	Standard Drive & Idler Pulley	MA	Flat top	0	25 (1)	11 (.43)	White	Acetal	Polyethylene	-40 (-40)	102 (215)	Y	Good	V-Good	5	N/A
		MB	Flat top	0	25 (1)	11 (.43)	White	Polypropylene	Polypropylene	5 (40)	135 (275)	Y	V-Good	Good	5	N/A
		MC	Flush grid	35	25 (1)	10 (.39)	White	Acetal	Polypropylene	5 (40)	93 (200)	Y	Good	V-Good	5	N/A
		MD	Flush grid	35	25 (1)	10 (.39)	White	Polypropylene	Polypropylene	5 (40)	105 (220)	Y	V-Good	Good	5	N/A
	Nose Bar Drive or Nose Bar Idler	MG	Flat top	0	13 (.5)	10 (.39)	White	Acetal	Nylon	-40 (-40)	93 (200)	Y	Good	Good	5	25 (1)
		MH	Flat top	0	13 (.5)	10 (.39)	White	Polypropylene	Nylon	5 (40)	105 (220)	Y	V-Good	V-Good	5	25 (1)
		MJ	Flush grid	25	13 (.5)	10 (.39)	White	Acetal	Nylon	-40 (-40)	93 (200)	Y	Good	Good	5	25 (1)
		MK	Flush grid	25	13 (.5)	10 (.39)	White	Polypropylene	Nylon	5 (40)	105 (220)	Y	V-Good	V-Good	5	25 (1)
Cleated Straight Belts	Standard Drive and Idler Pulley	NA	Flat Top w/25 (1) Cleats	0	25 (1)	11 (.43)	White	Acetal	Polyethylene	-40 (-40)	102 (215)	Y	Good	V-Good	60	N/A
		NB	Flat Top w/25 (1) Cleats	0	25 (1)	11 (.43)	White	Polypropylene	Polypropylene	5 (40)	135 (275)	Y	V-Good	Good	60	N/A
		NC	Flat Top w/75 (3) Cleats	0	25 (1)	11 (.43)	White	Acetal	Polyethylene	-40 (-40)	102 (215)	Y	Good	V-Good	60	N/A
		ND	Flat Top w/75 (3) Cleats	0	25 (1)	11 (.43)	White	Polypropylene	Polypropylene	5 (40)	135 (275)	Y	V-Good	Good	60	N/A
		NE	Flush Grid w/25 (1) Cleats	35	25 (1)	10 (.39)	Blue/White†	Acetal	Polypropylene	5 (40)	93 (200)	Y	Good	V-Good	60	N/A
		NF	Flush Grid w/25 (1) Cleats	35	25 (1)	10 (.39)	White	Polypropylene	Polypropylene	5 (40)	105 (220)	Y	V-Good	Good	60	N/A
		NG	Flush Grid w/75 (3) Cleats	35	25 (1)	10 (.39)	Blue/White†	Acetal	Polypropylene	5 (40)	93 (200)	Y	Good	V-Good	60	N/A
		NH	Flush Grid w/75 (3) Cleats	35	25 (1)	10 (.39)	White	Polypropylene	Polypropylene	5 (40)	105 (220)	Y	V-Good	Good	60	N/A
Friction Top Straight Belts	Standard Idler Pulley	See Table Below	Flat top w/friction inserts	0	25 (1)	14 (.55)	White	Polypropylene	Polypropylene	5 (40)	60 (140)	Y	V-Good	Poor	30	N/A
		See Table Below	Flush grid w/friction inserts	35	25 (1)	14 (.55)	White	Polypropylene	Polypropylene	5 (40)	60 (140)	Y	V-Good	Poor	30	N/A
Curved Flat Belts	Standard and Nose Bar Idler Pulley	XA	Plain Chain	0	25 (1)	13 (.51)	White	Acetal	Polypropylene	-20 (-4)	60 (140)	Y	Good	V-Good	5	N/A
		XB	Friction Insert	0	25 (1)	13 (.51)	White	Acetal	Polypropylene	-20 (-4)	60 (140)	Y	Good	V-Good	30	N/A

* FDA = Food and Drug Administration, CFIA = Canadian Food Inspection Agency

** Temperature, environmental conditions, product materials and product configuration effect the maximum incline or decline. Product testing is recommended.

*** These do not indicate ambient running conditions. Ambient temperature range is -1 to 38 C (30 to 100 F).

Product temperature is dependent on length of time product is in direct contact with belt surface. Product testing is recommended.

†Belt color dependent on belt width selection

FRICION TOP STRAIGHT PLASTIC CHAIN: Part number reference chart

Flat Top w/ Friction Inserts Part Number Reference	TA	TB	TC	TD	TE
Flush Grid w/ Friction Inserts Part Number Reference	N/A	TF	TG	TH	TJ
Friction Insert Spacing	25 mm (1 in)	51 mm (2 in)	102 mm (4 in)	152 mm (6 in)	305 mm (12 in)

Note: Friction Top not available on nose bar drives

GEARMOTOR MOUNTING PACKAGE & GEARMOTOR SELECTION STEPS

- Step 1:** Select a **Gearmotor Mounting Package** (below).
- Step 2:** Use the **Belt Speed Chart** (page 46) to determine your desired belt speed based on conveyor type and mount package. See Gearmotor column.
- Step 3:** Locate the appropriate gearmotor chart (pages 47-48) in terms of **Painted vs. Stainless Steel** based on your gearmotor chart numbers

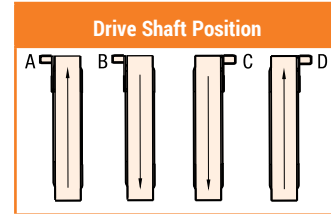

Bottom Mount Package, 90° Gearmotor

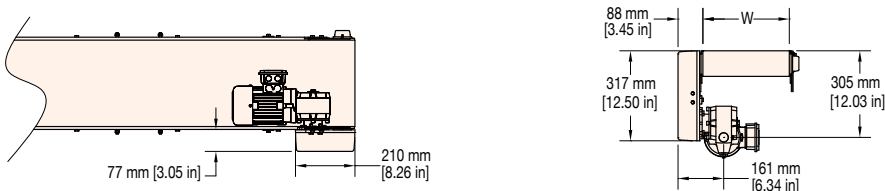

- Includes stainless steel gearmotor mounting bracket, timing belt, plated pulleys, guard and mounting hardware
- Conveyor belt speed can be adjusted with optional ratio pulley kits

W = Conveyor Belt Width

Side Mount Package, 90° Gearmotor

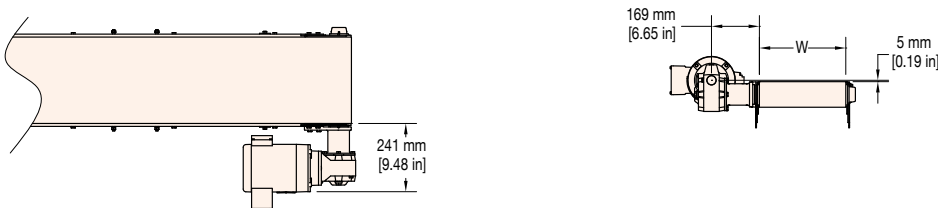

- Includes stainless steel gearmotor bracket, coupling and mounting hardware

W = Conveyor Belt Width

90° Gearmotor Location Options

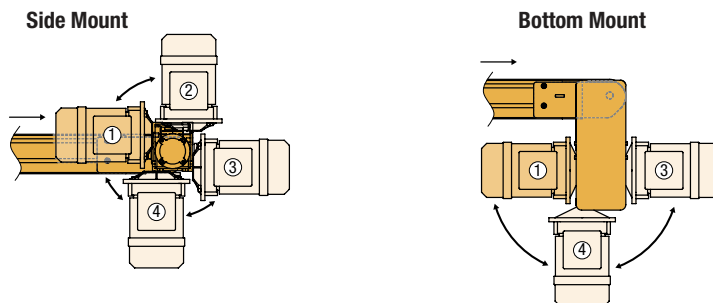

Due to the wide variety of drive set ups and applications, point of installation guarding is the responsibility of the end user.

Note: Conveyor and gearmotor are not included in the mounting package and must be ordered separately. Dimensions = mm (in)

Nose Bar Mount Package, 90° Gearmotor

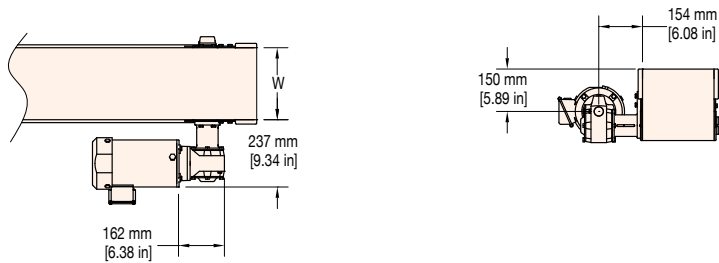

- Includes stainless steel gearmotor mounting bracket and mounting hardware

W = Conveyor Belt
Width

7350 Series: Gearmotor Mount Packages

7	3	X	B	S	S	T	S	A	G	S	C	S
												- Conveyor Sprocket: 30 = 30 Tooth, Blank = Side Drive
												- Gearmotor Sprocket: 30 = 30 Tooth, Blank = Side Drive
												- Drive Position: A or D
												- Gearmotor Size: S = Standard Load
												- Gearmotor Type: H = 90°
												- Drive Type: S = Side C = Center B = Bottom N = Nosebar P = Side and Powered Transfer
												- Configuration: S = Straight C = Curve
												- Conveyor Type: B = Belt C = Chain/Positive Drive
												- Language: Z = Universal

Due to the wide variety of drive set ups and applications, point of installation guarding is the responsibility of the end user.

Fixed Speed

Belt Speed						RPM From Gearmotor	Mount Package		Pulley Kit		Gearmotor Chart
Belted Conveyor		Modular Belt		Positive Drive Belt			Bottom	Side	Drive Pulley	Driven Pulley	
ft/min	m/min	ft/min	m/min	ft/min	m/min						
26	8	30	9	30	9	29	X	X	30	30	1,2
33	10	36	11	36	11	29	X		36	30	1,2
39	12	46	14	46	14	44	X	X	30	30	1,2
49	15	52	16	52	16	44	X		36	30	1,2
52	16	59	18	59	18	58	X	X	30	30	1,2
62	19	72	22	72	22	58	X		36	30	1,2
79	24	89	27	89	27	87	X	X	30	30	1,2
95	29	105	32	105	32	87	X		36	30	1,2
108	33	118	36	118	36	117	X	X	30	30	1,2
128	39	141	43	144	44	117	X		36	30	1,2
161	49	177	54	177	54	175	X	X	30	30	1,2
194	59	213	65	213	65	175	X		36	30	1,2

Variable Speed

Belt Speed						RPM at 60Hz Gearmotor	Mount Package		Pulley Kit		Gearmotor Chart
Belted Conveyor		Modular Belt		Positive Drive Belt			Bottom	Side	Drive Pulley	Driven Pulley	
ft/min	m/min	ft/min	m/min	ft/min	m/min						
3 to 26	1 to 8	3 to 30	1 to 9	3 to 30	1 to 9	29	X	X	30	30	3,4
3 to 33	1 to 10	4 to 36	1 to 11	4 to 36	1 to 11	29	X		36	30	3,4
4 to 39	1 to 12	5 to 46	1 to 14	5 to 46	1 to 14	44	X	X	30	30	3,4
5 to 49	1 to 15	5 to 52	2 to 16	5 to 52	2 to 16	44	X		36	30	3,4
5 to 52	2 to 16	6 to 59	2 to 18	6 to 59	2 to 18	58	X	X	30	30	3,4
6 to 62	2 to 19	7 to 72	2 to 22	7 to 72	2 to 22	58	X		36	30	3,4
8 to 79	2 to 24	9 to 89	3 to 27	9 to 89	3 to 27	87	X	X	30	30	3,4
10 to 95	3 to 29	10 to 105	3 to 32	10 to 105	3 to 32	87	X		36	30	3,4
11 to 108	3 to 33	12 to 118	4 to 36	12 to 118	4 to 36	117	X	X	30	30	3,4
13 to 128	4 to 39	14 to 141	4 to 43	14 to 144	4 to 44	117	X		36	30	3,4
16 to 161	5 to 49	18 to 177	5 to 54	18 to 177	5 to 54	175	X	X	30	30	3,4
19 to 194	6 to 59	21 to 213	7 to 65	21 to 213	7 to 65	175	X		36	30	3,4

Fixed Speed

Chart 1							
<ul style="list-style-type: none"> • Nema 56C • IP 55 Protection Rating • Sealed Gearmotor with H1 FDA approved Lubricant • FDA approved white epoxy painted motor • Aluminum gearbox with sanitary coating • Totally enclosed non-ventilated motor • 3 Phase, 60 Hz 						<p>Regulatory Approvals</p>	
Part Number	RPM	Hp	kW	Volts	FLA	in.-lbs.	Nm
71M060HS423FN	29	0.5	0.37	230/460	1.6/0.8	442	50
71M040HS423FN	44	0.5	0.37	230/460	1.6/0.8	486	55
71M030HS423FN	58	1	0.74	208-230/460	3.5-3.2/1.6	487	55
71M020HS423FN	87	1	0.74	208-230/460	3.5-3.2/1.6	407	46
71M015HS423FN	117	1	0.74	208-230/460	3.5-3.2/1.6	470	53
71M010HS423FN	175	1.5	1.11	208-230/460	4.6-4.2/2.1	442	50

Chart 2							
<ul style="list-style-type: none"> • Nema 56C • IP 55 Protection Rating • Sealed Gearmotor with H1 FDA approved Lubricant • Stainless Steel motor • Aluminum gearbox with sanitary coating • Totally enclosed non-ventilated motor • 3 Phase, 60 Hz 						<p>Regulatory Approvals</p>	
Part Number	RPM	Hp	kW	Volts	FLA	in.-lbs.	Nm
71M060HVS423FN	29	0.5	0.37	230/460	1.6/0.8	442	50
71M040HVS423FN	44	0.5	0.37	230/460	1.6/0.8	486	55
71M030HVS423FN	58	1	0.74	208-230/460	3.5-3.2/1.6	487	55
71M020HVS423FN	87	1	0.74	208-230/460	3.5-3.2/1.6	407	46
71M015HVS423FN	117	1	0.74	208-230/460	3.5-3.2/1.6	470	53
71M010HVS423FN	175	1.5	1.11	208-230/460	4.6-4.2/2.1	442	50

CE Note: When buying a gearmotor only without the starter, the customer must supply their own on/off switch and motor overload protection to comply with the CE Safety Directive.

FLA = Full Load Amperes Some motors and gear reducers may normally operate hot to the touch. Consult factory for specific operating temperatures. **Note:** Dimensions = mm (in)

Variable Speed

Chart 3

- Nema 56C
- IP 55 Protection Rating
- Sealed Gearmotor with H1 FDA approved Lubricant
- FDA approved white epoxy painted motor
- Aluminum gearbox with sanitary coating
- Totally enclosed non-ventilated motor
- 3 Phase, 6 to 60 Hz
- Order controller separately

Regulatory Approvals

UL
SP

Part Number	RPM	Hp	kW	Volts	FLA	in.-lbs.	Nm
71M060HS423EN	29	0.5	0.37	230/460	1.6/0.8	442	50
71M040HS423EN	44	0.5	0.37	230/460	1.6/0.8	486	55
71M030HS423EN	58	1	0.74	208-230/460	3.5-3.2/1.6	487	55
71M020HS423EN	87	1	0.74	208-230/460	3.5-3.2/1.6	407	46
71M015HS423EN	117	1	0.74	208-230/460	3.5-3.2/1.6	470	53
71M010HS423EN	175	1.5	1.11	208-230/460	4.6-4.2/2.1	442	50

Chart 4

- Nema 56C
- IP 55 Protection Rating
- Sealed Gearmotor with H1 FDA approved Lubricant
- Stainless Steel motor
- Aluminum gearbox with sanitary coating
- Totally enclosed non-ventilated motor
- 3 Phase, 6 to 60 Hz
- Order controller separately

Regulatory Approvals

UL
SP

Part Number	RPM	Hp	kW	Volts	FLA	in.-lbs.	Nm
71M060HVS423EN	29	0.5	0.37	230/460	1.6/0.8	442	50
71M040HVS423EN	44	0.5	0.37	230/460	1.6/0.8	486	55
71M030HVS423EN	58	1	0.74	208-230/460	3.5-3.2/1.6	487	55
71M020HVS423EN	87	1	0.74	208-230/460	3.5-3.2/1.6	407	46
71M015HVS423EN	117	1	0.74	208-230/460	3.5-3.2/1.6	470	53
71M010HVS423EN	175	1.5	1.11	208-230/460	4.6-4.2/2.1	442	50

CE Note: When buying a gearmotor only without the starter, the customer must supply their own on/off switch and motor overload protection to comply with the CE Safety Directive.

FLA = Full Load Amperes Some motors and gear reducers may normally operate hot to the touch. Consult factory for specific operating temperatures. **Note:** Dimensions = mm (in)

Variable Speed Controllers

Chart A

Variable Speed Controllers

- Variable Frequency Drive
- IP 65 Plastic Enclosure
- Stainless Steel mounting hardware
- Digital Display
- Keypad with Start/Stop and Speed variation
- Includes cord to motor
- Power to controller by others
- UL Approved

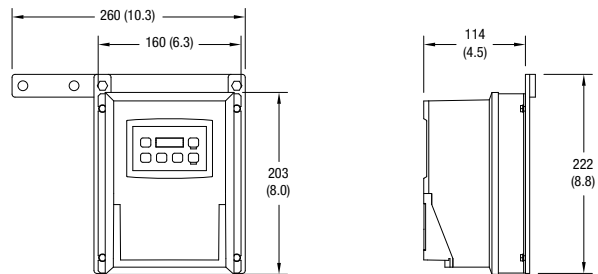

Part Number	Input			Output		Max Hp	Max Amps	A (width)	B (depth)
	Volts	Phase	Hz	Volts	Phase				
76MV1122S	115	1	60	230	3	0.5	2.2	7.9 (200)	3.8 (96)
76MV2322S	230	3	60	230	3	0.5	2.2	6.1 (155)	4.4 (112)
76MV1121S	115	1	60	230	3	1.0	4.0	7.9 (200)	4.9 (124)
76MV2121S	230	1	60	230	3	1.0	4.0	7.9 (200)	4.9 (124)
76MV4341S	460	3	60	460	3	1.0	2.0	6.1 (155)	4.4 (112)
76MV2127S	230	1	60	230	3	2.0	6.8	7.9 (200)	4.9 (124)
76MV2327S	230	3	60	230	3	2.0	6.8	7.9 (200)	4.9 (124)
76MV4347S	460	3	60	460	3	2.0	3.4	7.9 (200)	4.9 (124)

MANUAL MOTOR STARTER

Chart B

Manual Motor Starter

- Nema 4X Plastic Enclosure
- Stainless Steel mounting hardware
- IP 65
- Start / Stop Switch
- Lock-out tag-out capable
- Includes wiring to Motor
- Power to Starter by others
- No plug/cord set included

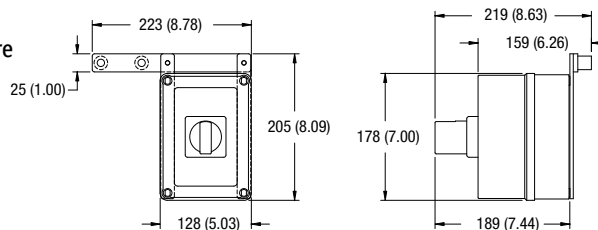

Part Number	Input			FLA
	Volts	Phase	Hz	
74MM11F	115	1	60	6.3 - 10
74MM21D	208-230	1	60	2.5 - 3.9
74MM23A	208-230	3	60	0.63 - 0.99
74MM23B	208-230	3	60	1.0 - 1.59
74MM23C	208-230	3	60	1.6 - 2.4
74MM23D	208-230	3	60	2.5 - 3.9
74MM23E	208-230	3	60	4.0 - 6.3
74MM43A	460	3	60	0.63 - 0.99
74MM43B	460	3	60	1.0 - 1.59
74MM43C	460	3	60	1.6 - 2.4
74MM43D	460	3	60	2.5 - 3.9

FLA = Full Load Amperes

Fixed Height Stands

- Welded open frame Stainless Steel construction with a 2B finish
- Adjustable angle connecting plate from 0° to 60 degrees
- For 152 mm (6 in) to 914 mm (36 in) Widths:
- ± 51 mm (2 in) of adjustment
- Optional swivel locking caster
- Optional diagonal brace for added stability
- For available heights see page 52



Support Stand with optional outrigger and diagonal brace shown

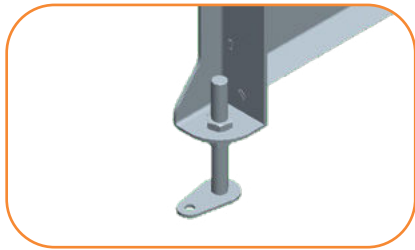

STANDARD FEATURE:
Fixed Foot

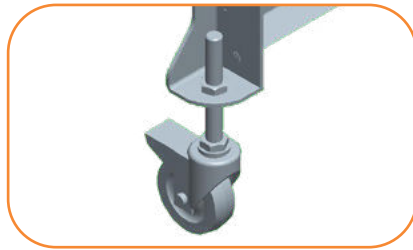

OPTIONAL:
Swivel Caster



OPTIONAL: Diagonal Brace

Outriggers

- Fixed height support stands are available with outriggers
- Outriggers provide added support for tall applications
- Welded Stainless Steel construction with 2B finish
- Extend stand width 316 mm (12.43 in)



Dimensions = mm (in)

Note: Due to the wide variety of conveyor and stand options along with possible configurations, stability of the final setup is the responsibility of the end user.

Tall Supports Stands

- Welded tubular Stainless Steel construction brushed to #4 finish
- ±50 mm (2 in) of adjustment
- Adjustable angle connecting plate from 0° to 60 degrees
- Includes diagonal brace for stability
- Tall Support Stands require the use of floor anchors
- For available heights see page 52



**STANDARD FEATURE:
Fixed Foot**



Tall Stand

Low Height Supports Stands

- All components are Stainless Steel brushed to #4 finish
- ±51 mm (2 in) of adjustment
- Fixed Foot self-aligns 10° for sloped floors
- Caster is swivel locking
- Horizontal conveyor mounts only
- For available heights see page 52

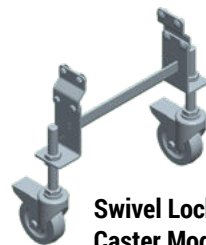

**Swivel Locking
Caster Model**



Fixed Foot Model

Dimensions = mm (in)

Note: Due to the wide variety of conveyor and stand options along with possible configurations, stability of the final setup is the responsibility of the end user.

Support Stand Heights

Type	Fixed Foot				Caster Foot			
	Shortest Stand		Tallest Stand		Shortest Stand		Tallest Stand	
	Minimum Top Of Belt	Maximum Top Of Belt	Minimum Top Of Belt	Maximum Top Of Belt	Minimum Top Of Belt	Maximum Top Of Belt	Minimum Top Of Belt	Maximum Top Of Belt
Fixed Height	350 (13.8)	450 (17.71)	1900 (74.8)	2000 (78.7)	450 (17.71)	550 (21.6)	2000 (78.7)	2100 (82.7)
Tall Support	1850 (72.8)	1950 (76.8)	2400 (94.5)	2500 (98.4)	N/A	N/A	N/A	N/A
Short Height	200 (7.87)	300 (11.8)	275 (10.8)	375 (14.7)	300 (11.8)	400 (15.7)	375 (14.7)	475 (18.7)

Note: Dimensions = mm (in)
 Height increments of 25 mm (1 in)
 Top of belt heights for Modular Belt Curve are 25 mm shorter

Fixed Height Support Stands Widths*

Conveyor Width	152	203	254	305	356	406	457	508	559	610	660	711	762	813	864	914
Conveyor Belt Width (W)	152	203	254	305	356	406	457	508	559	610	660	711	762	813	864	914
	(6)	(8)	(10)	(12)	(14)	(16)	(18)	(20)	(22)	(24)	(26)	(28)	(30)	(32)	(34)	(36)
Stand width	282	333	384	435	486	536	587	638	689	740	790	841	892	943	994	1044
	(11)	(13)	(15)	(17)	(19)	(21)	(23)	(25)	(27)	(29)	(31)	(33)	(35)	(37)	(39)	(41)

*Dimensions shown are nominal. Contact factory for specific layout and dimensions.
 *Contact factory for Tall and Low Height Support Stand configurations.

7350 Series: Support Stands

73 H X WWW - HHHH HHHH S S T T F

- Foot: F = Fixed Foot B = Fixed Foot with Brace (brace not on low height stands)
 C = Caster with Brace (brace not on low height stands)
- Stand Type: AM = Angle Mount AR = Angle Mount w/ Outriggers
 LH = Low Height Support Stand TA = Tall Angle Mount
- Configuration: S = Straight C = Curve
- Belt/Chain: B = Belt C = Chain (Modular Belt)
- Maximum Top of Belt Height = 0100 mm (4 in) more than minimum
- Minimum Top of Belt Height = 0200 to 2400 in 25 mm increments (8 - 94 in)
- Width (mm): 152 to 914 (6 - 36 in)
- Language: Z = Universal
- Type: H = H Type Support Stand

Dimensions = mm (in)

Note: Due to the wide variety of conveyor and stand options along with possible configurations, stability of the final setup is the responsibility of the end user.

Horizontal Ceiling Supports



Specifications

- All components are Stainless Steel brushed to #4 finish
- Includes a pair of mounting brackets and hardware for support on both sides of conveyor
- Compatible with 12 mm (0.5 in) threaded support rod (not provided)

Part Number	73HCS
-------------	-------

Adjustable Angle Ceiling Supports



Specifications

- All components are Stainless Steel brushed to #4 finish
- Includes a pair of mounting brackets and hardware for support on both sides of conveyor
- Compatible with 12 mm (0.5 in) threaded support rod (not provided)
- Mounting block pivots to support incline mounts from 0° to 60°

Part Number	73ACS
-------------	-------

Sanitary Floor Anchor Kits - Type 1

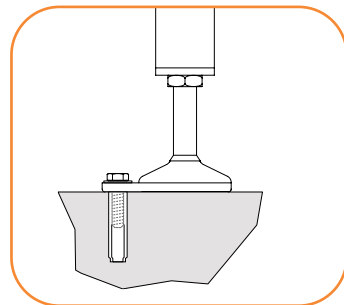

Specifications

- 10 mm (.375 in) x 40 mm (1.57 in) drop in
- Stainless Steel
- Anchor is flush with floor upon removal of bolt
- Two (2) per anchor kit

Part Number	FAS-1
-------------	-------

Sanitary Floor Anchor Kits - Type 2

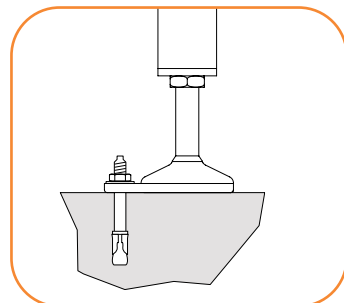

Specifications

- 10 mm (.375 in) x 70 mm (2.75 in)
- Stainless Steel
- Threaded anchor bolt protrudes above floor after installation
- Two (2) per anchor kit

Part Number	FAS-2
-------------	-------

Dimensions = mm (in)

Note: Due to the wide variety of conveyor and stand options along with possible configurations, stability of the final setup is the responsibility of the end user.

Accessory Mounting Bar



Specifications

- Used for mounting adjustable devices such as photoeyes and sensors
- Can be mounted directly to frame or in combination with guide brackets
- Includes 1248 mm (48 in) long bar with (3) mounting brackets
(Bar can be cut to length as needed)
- Compatible with Value Guide blocks (VG-021-02)
- All brackets and fasteners are Stainless Steel

Part Number	517509	Bar Assembly 1248 mm (48 in) long
-------------	--------	-----------------------------------

Photo Eye and Reflector Mounting Brackets

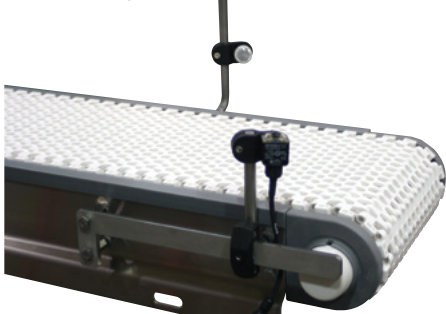

Specifications

- Mounts standard 18 mm (0.71 in) barrel or nose mount photo eyes or sensors
- Attach bracket or accessories without frame modifications
- Adjustable along the length of the conveyor
- Adjustable height and angle positioning
- All adjustment screws located outside the food zone
- (3) Photo Eye Types
 - Thru beam includes (2) mounts
 - Reflector includes (1) photo eye mount and (1) reflector mount (reflector included)
- Accessory Mounting Bar Style: (3) Mount versions:
 - To fixed post (does not include mounting post)
 - To fixed post (includes mounting post)
 - To accessory mounting bar (includes Value Guide Block and adjustable post)

7350 Series: Photo Eye Bracket - Accessory Mounting Bar Style

7352	P	M	-	F	P
				Post Type: NP = Fixed Post w/o post included	
				FP = Fixed Post w/ post included	
				AM = Accessory Mount	
	Mount Type: PM = Photoeye Mount			RM = Reflective Mount	
				CM = Convergent Mount	

Dimensions = mm (in)

Note: Due to the wide variety of conveyor and stand options along with possible configurations, stability of the final setup is the responsibility of the end user.

Roller Transfer Plate

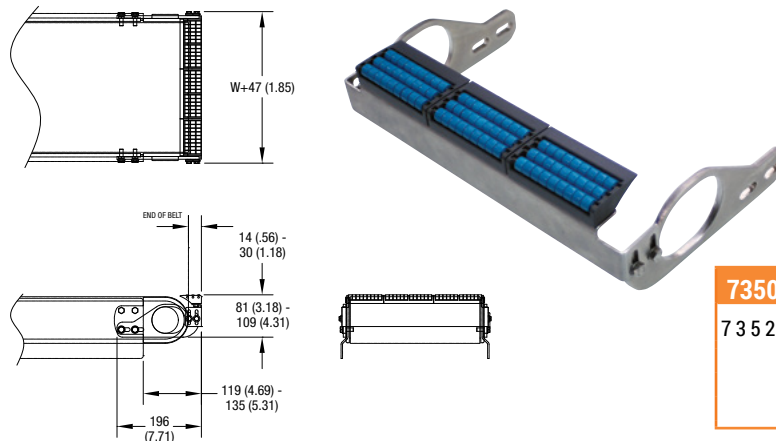

Specifications

- 150 mm (6 in) wide to 914 mm (36 in) wide
- Includes 1 mm (0.43 in) diameter rollers mounted in transfer plate
- Adjustable mounting to fine tune small parts transfer
- All brackets and fasteners are Stainless Steel

7350 Series: Roller Transfer Plate

7352T - X - W W

Conveyor Width: 152 - 914 mm (6 - 36 in)
 Belt Type: B = Belted C = Modular Belt Curve
 M = Modular Belt Straight P = Positive Drive

Overhead Guide



Specifications

- For part hold down or cover closing
- Adjustable height and position across width
- Round nose UHMW guide with stainless steel backing
- Lengths: 914 mm (36 in) to 3048 mm (1200 in) in 25 mm (1 in) increments
- Horizontal Brackets provided for every 609 mm (24 in) of length
- Available in standard adjustable and tool-less adjustable mount styles
- All brackets and fasteners are Stainless Steel
- Does not include vertical mounting post. To be used with profiles 13 thru 18 or upper guide assembly

7350 Series: Overhead Guide

7352HG A - L L

Guide Length: 914 - 3048 mm (36 - 120 in)
 Guide Type: A = Adjustable T = Tool-less

Drip Pans



Specifications

- Widths: 152 mm (6 in) to 1524 mm (60 in) available in 50 mm (2 in) increments
- Lengths: 610 mm (24 in) to 25375 mm (999 in) available in 25 mm (1 in) increments maximum section lengths of 2997 mm (118 in)
- Tool-less hook design for fast removal and rapid cleaning
- Provides a 50 mm (2 in) window for clean-out access without removal
- All pans equipped with a 25 mm (1 in) containment lip on all sides
- Contact factory for additional options and ordering

Dimensions = mm (in)

Note: Due to the wide variety of conveyor and stand options along with possible configurations, stability of the final setup is the responsibility of the end user.

Regulatory Approvals:







Conveyors:

All Dorner 7350 Series standard conveyors (not including gearmotors and controllers) are CE approved. CE approval follows the provisions of the following directives; Machine Directive 2006/42/EC, EU Low Voltage Directive 2006/95/EC, and EMC Directive 2004/108/EC. All conveyors are marked with the CE symbol on the Dorner serial number tag located on the conveyor frame. Contact the factory for the CE Declaration of Conformity.

All Dorner 7350 Series standard conveyors (not including gearmotors and controllers) are designed and manufactured in accordance with the restrictions defined in the "Restriction of Hazardous Substances" directive, citation 2002/95/EC, commonly known as RoHS. All conveyors are marked with the RoHS symbols on the Dorner serial number tag located on the conveyor frame.

Gearmotors and Controllers:

All Dorner 7350 Series gearmotors and controllers carry one or more of the following approvals. Products are not covered by each approval. Please see the appropriate part number on the Gearmotor and controller charts located in this manual. In addition, regulatory symbols are located on the product information tags located on the product.

	<p>CE Marking on a product is a manufacturer's declaration that the product complies with the essential requirements of the relevant European health, safety and environmental protection legislation, in practice by the Product Directives. CE Marking on a product ensures the free movement of the product within the European Union (EU).</p>
	<p>This directive restricts (with exceptions) the use of six hazardous materials in the manufacture of various types of electronic and electrical equipment. It is closely linked with the Waste Electrical and Electronic Equipment Directive (WEEE) 2002/96/EC which sets collection, recycling and recovery targets for electrical goods and is part of a legislative initiative to solve the problem of huge amounts of toxic e-waste.</p>
	<p>The UL Recognized Component mark is for products intended to be installed in another device, system or end product. This Recognized Component Mark is for the United States only. When a complete product or system containing UL Recognized Components is evaluated, the end-product evaluation process can be streamlined.</p>
	<p>The UL Recognized Component mark is for products intended to be installed in another device, system or end product. This Recognized Component Mark is for the United States and Canada. When a complete product or system containing UL Recognized Components is evaluated, the end-product evaluation process can be streamlined.</p>
	<p>CSA International (Canadian Standards Association), is a provider of product testing and certification services for electrical, mechanical, plumbing, gas and a variety of other products. Recognized in the U.S., Canada and around the world, CSA certification marks indicate that a product, process or service has been tested to a Canadian or U.S. standard and it meets the requirements of an applicable CSA standard or another recognized document used as a basis for certification.</p>
	<p>The UL Listing Mark means UL found that representative product samples met UL's safety requirements. These requirements are primarily based on UL's own published standards for safety. The C-UL-US Mark indicates compliance with both Canadian and U.S. requirements. The products with this type of Mark have been evaluated to Canadian safety requirements and U.S. safety requirements.</p>

Baking Industry Standards and Certifications:

AquaGard 7350 Series Conveyors are often used in food production or food packaging areas where proper design of equipment is essential to maintain proper food safety. AquaGard 7350 Series conveyors are designed for light wash down environments typically seen in packaged food, dry food production or confectionary production. In these applications the correct installation and application of the conveyor is critical to the proper running of the conveyor and maintaining proper food safety. The end user must ensure that the conveyor belts are properly tracked and the conveyor is properly installed as defined by Dorner.

All AquaGard 7350 Series products are designed and constructed to be used in dry food or packaged food production environments. The following AquaGard products have gone through testing and certification and are certified to BISSC standard, design requirements for Conveyors section of ANSI/ASB/Z50.2-2015.

- 7350 Series Belted Conveyor**
- 7350 Series Modular Belt Conveyor**
- 7350 Series Positive Drive Belted Conveyor**

Contact the factory for copy of the certification.



Materials and Chemical Resistance:

Conveyor Frames, Plastics and Modular Belting	
The following is a list of base materials used in the 7350 Series conveyor:	
Material	Conveyor Component
Acetal Copolymer, POM	Modular Belts, molded bearing housings
Polypropylene, PP	Modular Belts
Polyamide, PA	Adjustable Guide Support Brackets
UHMW-PE	Modular Belt Slide Rail, Adjustable Guide Face
Thermoplastic Elastomer, TPE	Modular Belt Friction Insert

The materials used in the 7350 Series product can resist many chemicals, however some should be avoided. Avoid the following:

- Acids with PH less than 4
- Bases with PH higher than 9

Resistance to Materials: Conveyor Frames, Plastics and Modular Belting				
The following table provides the resistance to materials used in the conveyor to several chemicals. Application testing is recommended to determine long term material durability.				
Legend:				
1 = Very good resistance 2 = Good resistance 3 = Moderate resistance 4 = Not recommended X = no data available				
Acids	Acetal POM	Polypropylene	Polyamide PA	UHMW-PE
Acetic acid	3	1	4	1
Benzoic acid	3	1	4	1
Boric acid	3	1	2	1
Citric acid	3	1	2	1
Chromic acid	4	1	4	1
Hydrofluoric acid	4	1	4	1
Hydrochloric acid	4	1	4	1
Hydro cyanic acid	4	X	4	1
Nitric acid	4	1	4	1
Oleic acid	3	1	2	1
Oxalic acid	4	1	2	1
Phosphoric acid	4	1	4	1
Sulphuric acid	4	2	4	1
Tartaric acid	3	1	2	1
Basic Compounds	Acetal POM	Polypropylene	Polyamide PA	UHMW-PE
Ammonia	1	1	2	1
Calcium hydroxide	1	X	2	1
Caustic soda	1	X	2	1
Potassium hydroxide	1	1	2	1

Resistance to Materials: Conveyor Frames, Plastics and Modular Belting (continued)

Legend:

1 = Very good resistance | 2 = Good resistance | 3 = Moderate resistance |
4 = Not recommended | X = no data available

Salts	Acetal POM	Polypropylene	Polyamide PA	UHMW-PE
Potassium bicarbonate	2	X	2	1
Potassium permanganate	2	2	4	1
Sodium cyanic	2	X	2	1
Sodium hydrochloride	3	X	4	1
Acid salt	2	X	3	1
Basic salt	1	X	2	1
Neutral salt	1	X	2	1
Organic Compounds	Acetal POM	Polypropylene	Polyamide PA	UHMW-PE
Acetone	1	1	1	1
Aniline	2	1	3	1
Benzene	1	3	2	4
Benzine	2	X	2	3
Butyl alcohol	2	X	2	1
Carbon disulphide	1	3	2	3
Carbon tetrachloride	1	3	1	3
Chloroform	1	4	3	4
Ethyl acetate	1	1	2	1
Ethyl alcohol	1	X	2	1
Heptane	2	1	1	2
Methyl alcohol	1	X	2	1
Methyl ethyl ketone	1	2	1	2
Nitrobenzene	2	2	2	1
Phenol	3	1	4	1
Gases	Acetal POM	Polypropylene	Polyamide PA	UHMW-PE
Carbon dioxide	3	1	1	1
Carbon monoxide	2	X	1	1
Chlorine	2	4	4	3
Hydrogen Sulfide	3	1	1	1
Sulphur dioxide	2	1	3	1
Other	Acetal POM	Polypropylene	Polyamide PA	UHMW-PE
Carbon tetrachloride	1	3	1	3
Beer	1	1	2	1
Fruit juice	1	2	2	1
Gasoline	1	1	2	1
Milk	1	1	1	1
Oil	1	3	1	1
Vinegar	1	1	2	1

Belting:

The following is a list of the top coat materials used in 7350 Series conveyor belting:

Material	Belt Number
Urethane	01, 02, 03, 05, 06, 09, 54, 55, 56, 53, 60, 61, 63, 68, 69, 72, 73, 75, 76, 77
PVC (non FDA approved)	08, 18, 59, 64
Silicone	50, 80, 81
Polyester	66
Nitrile	57
Urethane (hard)	58

Resistance to Materials: Belting

The following table provides the resistance to belt materials used in the conveyor to several chemicals. Application testing is recommended to determine long term material durability.

Legend:

1 = Good resistance | 3 = Limited resistance | 4 = Not recommended

Materials	Urethane	PVC (non FDA)	Silicone	Polyester	Urethane (hard)
Chemicals					
Acetic acid (glacial acetic acid)	4	3	1	1	4
Acetic acid 10 %	3	1	1	3	1
Acetic anhydride	3	4	1	1	4
Acetone	4	4	1	3	4
Aluminium salts	1	1	1	1	1
Alum	1	1	1	1	1
Ammonia, aqueous	3	1	1	3	1
Ammonia, gaseous	1	1	3	1	1
Ammonium acetate	1	1	1	1	1
Ammonium carbonate	1	1	1	1	1
Ammonium chloride	1	1	1	1	1
Ammonium nitrate	1	1	1	1	1
Ammonium phosphate	1	1	1	1	1
Ammonium sulphate	1	1	1	1	1
Amyl alcohol	1	4	3	1	1
Aniline	3	3	3	4	4
Barium salts	1	1	1	1	1
Benzaldehyde	4	4	4	4	4
Benzine (see also Motor fuels)	1	3	3	1	1
Benzoic acid	1	1	1	1	1
Benzol	3	4	4	3	3
Boric acid	1	1	1	1	1
Boric acid, solution	1	1	1	1	1
Bromine	4	4	4	4	4
Bromine water	4	3	1	4	3
Butane, gaseous	1	1	1	1	1
Butane, liquid	1	1	1	1	1
Butyl acetate	4	4	4	3	4
n-Butyl alcohol	1	3	1	1	1
Calcium chloride	1	1	1	1	1

Resistance to Materials: Belting (continued)					
Legend: 1 = Good resistance 3 = Limited resistance 4 = Not recommended					
Materials	Urethane	PVC (non FDA)	Silicone	Polyester	Urethane (hard)
Calcium nitrate	1	1	1	1	1
Calcium sulphate	1	1	1	1	1
Carbon disulphide	4	4	3	4	4
Carbon tetrachloride	3	4	4	4	3
Chlorine, liquid	4	4	4	4	4
Chlorine, gaseous, dry	4	4	4	4	4
Chlorine, gaseous, wet	4	4	4	4	4
Chlorine water	4	1	3	4	3
Chlorobenzene	4	4	4	4	4
Chloroform	4	4	4	4	4
Chlorosulphonic acid	4	4	4	4	4
Chromic acid	4	4	4	4	4
Chromium salts	1	1	1	1	1
Chromium trioxide	1	1	1	1	1
Citric acid	4	1	1	1	4
Copper salts	1	1	1	1	3
Cresols	3	3	3	4	3
Cresols, aqueous	3	3	3	3	3
Cyclohexane	4	4	4	1	4
Cyclohexanol	4	4	4	4	4
Cyclohexanone	4	4	4	4	4
Decahydronaphthalene	4	4	4	4	4
Dibutyl phthalate	3	4	1	4	4
Diethyl ether	4	4	4	4	4
Dimethyl formamide	4	4	3	4	4
1.4 Dioxan	4	4	3	4	4
Ether	4	4	4	4	4
Ethyl acetate	4	4	4	3	4
Ethyl alcohol, non-denatured 100%	1	3	3	1	1
Ethyl alcohol, non-denatured 96%	1	3	3	1	1
Ethyl alcohol, non-denatured 50%	1	3	3	1	1
Ethyl alcohol, non-denatured 10%	1	3	1	1	1
Ethyl benzene	4	4	4	4	4
Ethyl chloride	4	4	4	4	4
Ethylene chloride	4	4	4	4	4
2-Ethyl hexanol	1	3	1	1	1
Formaldehyde	1	3	1	3	1
Formic acid, dilute	4	1	1	3	3
Glycerine	1	1	1	1	1
Glycerine, aqueous	1	1	1	1	1
Glycol	1	3	1	1	1
Glycol, aqueous	1	1	1	1	1
Heptane	1	3	3	1	1
Hexane	1	3	3	1	1
Hydrochloric acid, conc.	3	1	4	3	1

Resistance to Materials: Belting (continued)					
Legend: 1 = Good resistance 3 = Limited resistance 4 = Not recommended					
Materials	Urethane	PVC (non FDA)	Silicone	Polyester	Urethane (hard)
Hydrochloric acid 10 %	3	1	1	1	1
Hydrofluoric acid 40 %	4	4	4	4	4
Hydrogen chloride, gaseous, dilute	3	1	3	3	1
Hydrogen chloride, gaseous, conc.	3	3	3	4	3
Hydrogen peroxide 10%	3	1	1	3	1
Hydrogen sulphide	3	3	3	3	3
Iron salts (sulphate)	1	1	1	1	1
Isooctane	1	3	3	1	1
Isopropyl alcohol	1	3	1	1	1
Lactic acid	1	3	1	1	1
Magnesium salts	1	1	1	1	1
Mercury	1	1	1	1	1
Mercury salts	1	1	1	1	1
Methyl alcohol, aqueous 50 %	3	3	1	1	1
Methyl alcohol (methanol)	1	3	1	1	1
Methyl ethyl ketone	4	4	1	3	4
Methylene chloride	4	4	4	4	4
Naphthalene	3	4	4	3	4
Nickel salts	1	1	1	1	1
Nitric acid	4	3	4	4	4
Nitrobenzene	4	4	1	3	4
Octane (see also isooctane)	1	3	4	1	1
Oleic acid	1	3	4	1	1
Oxalic acid	1	1	1	1	1
Ozone	1	3	3	1	3
Perchloroethylene	4	4	4	4	4
Phenol	3	3	1	4	3
Phenol, aqueous	4	3	1	4	3
Phosphoric acid 85 %	4	1	1	3	1
Phosphoric acid 50 %	1	1	1	1	1
Phosphoric acid 10 %	1	1	1	1	1
Phosphorus pentoxide	1	1	1	1	1
Potash lye 50 %	4	1	4	3	4
Potash lye 25 %	4	1	4	1	4
Potash lye 10 %	4	1	3	1	4
Potassium carbonate (potash)	1	1	1	1	1
Potassium chlorate	1	1	1	1	1
Potassium chloride	1	1	1	1	1
Potassium dichromate	1	1	1	1	1
Potassium iodide	1	1	1	1	1
Potassium nitrate	1	1	1	1	1
Potassium permanganate	1	1	1	1	1
Potassium persulphate	1	1	1	1	1
Potassium sulphate	1	1	1	1	1
Propane, gaseous	1	1	1	1	1

Resistance to Materials: Belting (continued)					
Legend: 1 = Good resistance 3 = Limited resistance 4 = Not recommended					
Materials	Urethane	PVC (non FDA)	Silicone	Polyester	Urethane (hard)
Propane, liquid	1	1	1	1	1
Pyridine	4	4	3	4	4
Silver salts	1	1	1	1	1
Soda lye 50% (see potash lye)	4	1	4	4	4
Soda lye 25%	4	1	4	3	4
Soda lye 10%	4	1	3	1	4
Sodium bisulphite	1	1	1	1	1
Sodium carbonate (natron)	1	1	1	1	1
Sodium carbonate (soda)	1	1	1	1	1
Sodium chlorate	1	1	1	1	1
Sodium chloride (common salt)	1	1	1	1	1
Sodium hydroxide (caustic soda)	4	1	4	1	4
Sodium hypochlorite	1	1	1	3	1
Sodium nitrate	1	1	1	1	1
Sodium nitrite	1	1	1	1	1
Sodium perborate	1	1	1	1	1
Sodium phosphate	1	1	1	1	1
Sodium sulphate (Glauber salt)	1	1	1	1	1
Sodium sulphide	1	1	1	1	1
Sodium sulphite	1	1	1	1	1
Sodium thiosulphate (fixing salt)	1	1	1	1	1
Stearic acid	1	1	1	1	1
Succinic acid	1	1	1	1	1
Sulphur	1	1	1	1	1
Sulphur dioxide	3	3	3	3	4
Sulphuric acid 96%	4	4	4	4	4
Sulphuric acid 50%	4	3	4	3	4
Sulphuric acid 25%	4	3	3	1	3
Sulphuric acid 10%	4	3	1	1	3
Tartaric acids	1	1	1	1	1
Tetrachloroethane	4	4	4	4	4
Tetrachloroethylene (perchloroethylene)	4	4	4	4	4
Tetrahydrofuran	4	4	4	4	4
Tetrahydronaphthalene	4	4	4	4	4
Thiophene	4	4	4	4	4
Tin II chlorides	1	1	1	1	1
Toluene	4	4	4	4	4
Trichloroethylene	4	4	4	4	4
Urea, aqueous	1	1	1	1	1
Water	1	1	1	1	1
Xylene	4	4	4	3	4
Zinc salts	1	1	1	1	1

Resistance to Materials: Belting (continued)

Legend:

1 = Good resistance | 3 = Limited resistance | 4 = Not recommended

Materials	Urethane	PVC (non FDA)	Silicone	Polyester	Urethane (hard)
Products					
Alum	1	1	1	1	1
Anti-freeze*	1	3	1	1	1
Aqua regia	4	4	4	4	4
Asphalt	1	3	3	1	1
Battery acid	4	4	4	4	4
Benzine	1	3	3	1	1
Bleaching lye (12.5%)	1	1	1	1	3
Bone oil	1	3	4	1	1
Borax	1	1	1	1	1
Brake fluid* Bosch	1	3	1	1	3
Brake fluid* Skydrol	4	4	3	4	4
Chloride of lime (aqueous suspension)	1	1	1	1	3
Chlorine (active)	4	4	4	4	4
Chrome baths* (technical)	1	3	3	1	1
Chromosulphuric acid	4	4	4	4	4
Cresol solution	3	3	4	4	4
Diesel oil	1	1	3	1	1
Fertilizer salts	1	1	1	1	1
Fixing salt	1	1	1	1	1
Floor wax	1	3	3	1	1
Formalin	1	3	3	1	1
Fuel oils*	1	1	3	1	1
Furniture polish*	1	3	3	1	1
Gypsum	1	1	1	1	1
Ink*	1	1	1	1	1
Linseed oil	1	3	1	1	1
Litex (styrene)	4	4	4	4	4
Mineral oils (non-aromatic)	1	1	1	1	1
Moth balls	3	4	3	3	3
Diesel oil*	1	1	3	1	1
Petrol (gasoline) DIN51635	1	3	3	1	1
Petrol, regular	1	3	3	1	1
Petrol, super	3	4	3	1	3
Motor oils*	1	1	1	1	1
Oil no. 3 (ASTM)	1	3	1	1	1
Oleum	4	4	4	4	4
Paraffin	1	1	1	1	1
Paraffin oil	1	1	1	1	1
Petroleum	1	3	3	1	1
Petroleum ether	1	3	4	1	1
Photographic developer	1	1	1	1	1

Bearings and Lubrication:

All bearings on AquaGard 7350 Series Conveyors are sealed and lubricated for life. No grease zerk is available and no greasing over the life of the product is required.

All gearmotors used on AquaGard 7350 Series conveyor are sealed and may be mounted in any position. Changing gear oil lubrication may be needed over the life of the gearbox. Please check the appropriate gearmotor manual for instructions.

Support Stand Locations:

Support Stand Locations			
Symbol	Description	Distance	
		mm	in
A	Maximum distance back at drive end	610	24
B	Maximum distance back at idler end	762	30
C	Maximum distance between supports	2997	118

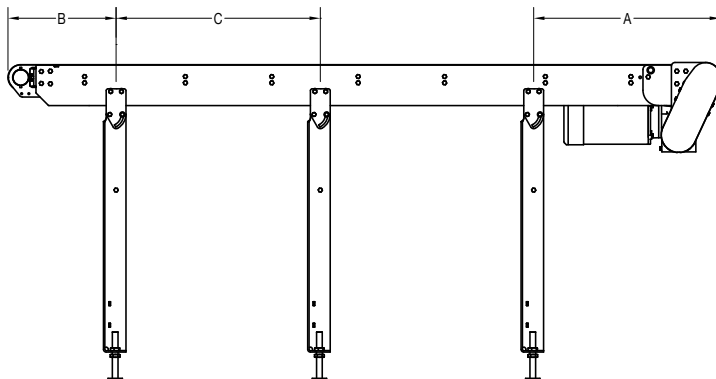

Note: Dimensions = mm (in)

Conveyor Drive Shaft Tolerances:

End Drive, Belted and Modular Belt:

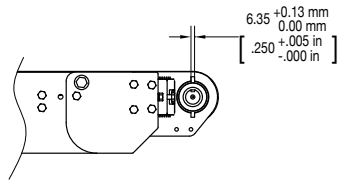
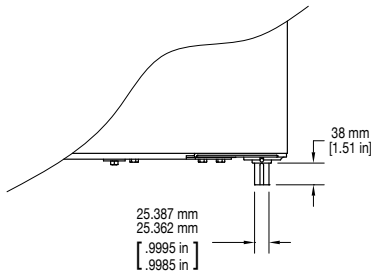

Center Drive:

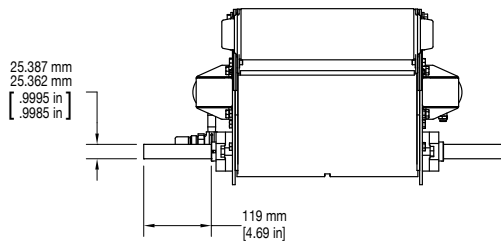
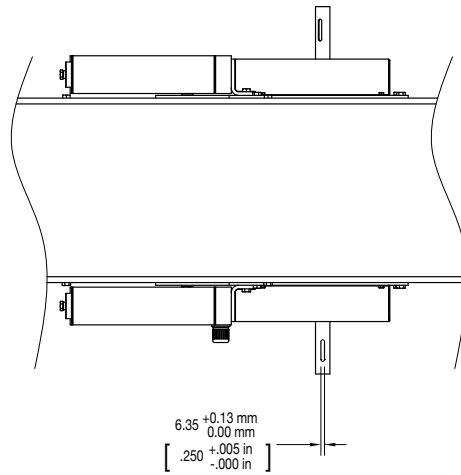

Conveyor Noise Level (Decibel Ratings)

The actual noise level generated by the conveyor depends on several factors; the installation configuration, the product running on the conveyor, the surrounding equipment, the conveyor options and belt speed. The noise level generated by the conveyor is typically less than the general noise level of factory equipment.

Generally a higher belt speed will result in a higher noise level. In addition modular belt conveyors will run slightly louder than belted conveyors. The following charts provide basic decibel ratings for a typical conveyor arrangements.

Belted Conveyors:

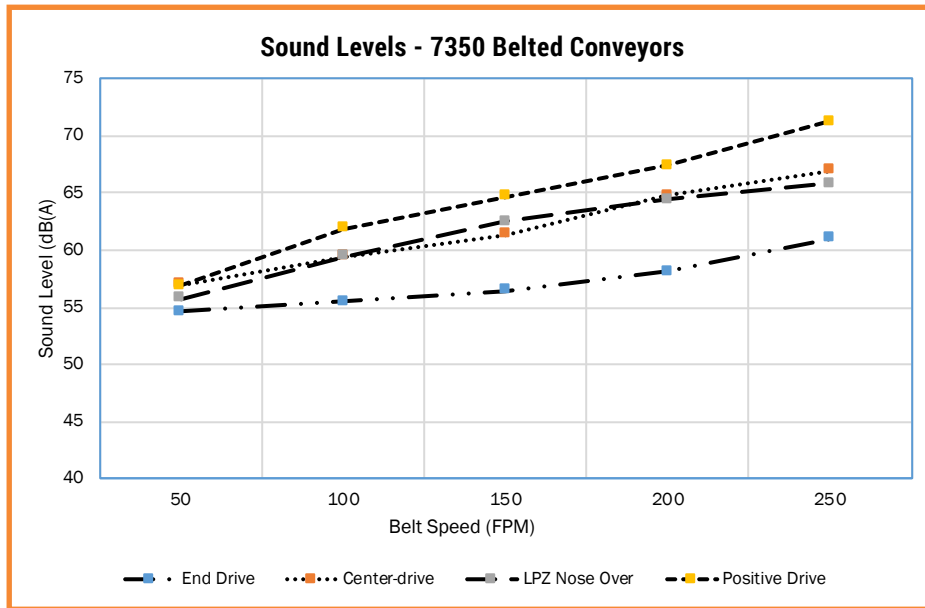

Modular Belt Conveyors:

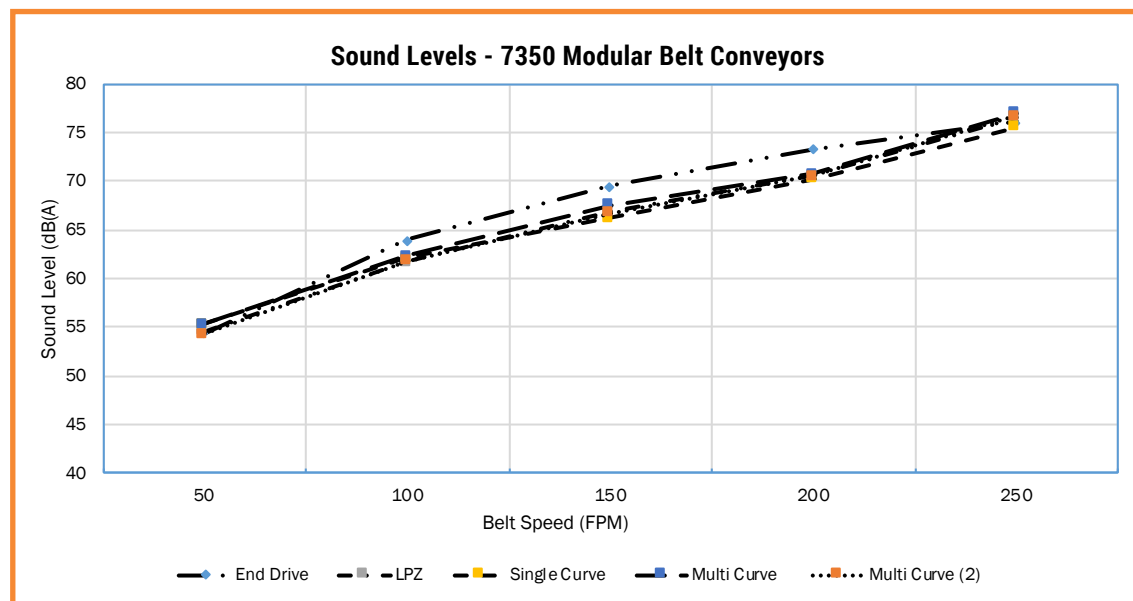

Maximum Load Capacity

The following Load Capacity Charts **do not** take into account the conveyor configuration, length or gearmotor selection. Your specific conveyor may not be capable of the maximum load condition. Please confirm your maximum load per application with the Dorner DTools program at www.dornerconveyors.com.

All load capacities shown are non-accumulated evenly distributed loads.

7350 Series Belted End Drive Conveyor					
Belt Width		Pulling the Belt		Pushing the Belt	
mm	in	Kg	Lb	Kg	Lb
152	6	114	250	57	125
203	8	136	300	68	150
254	10	159	350	80	175
305	12	182	400	91	200
356	14	205	450	103	225
406	16	227	500	114	250
457	18	227	500	114	250
508	20	227	500	114	250
559	22	227	500	114	250
610	24	227	500	114	250
660	26	227	500	114	250
711	28	227	500	114	250
762	30	227	500	114	250
813	32	227	500	114	250
864	34	227	500	114	250
914	36	227	500	114	250

7350 Series Belted Center Drive Conveyor			
Belt Width		Pulling the Belt	
mm	in	Kg	Lb
152	6	114	250
203	8	136	300
254	10	159	350
305	12	182	400
356	14	205	450
406	16	227	500
457	18	227	500
508	20	227	500
559	22	227	500
610	24	227	500
660	26	227	500
711	28	227	500
762	30	227	500
813	32	227	500
864	34	227	500
914	36	227	500

Maximum Load Capacity (continued)

7350 Series Modular Belt Conveyor			
Belt Width		Pulling the Belt	
mm	in	Kg	Lb
203	8	205	450
254	10	227	500
305	12	250	550
356	14	273	600
406	16	295	650
457	18	318	700
508	20	341	750
559	22	341	750
610	24	341	750
660	26	341	750
711	28	341	750
762	30	341	750
813	32	341	750
864	34	341	750
914	36	341	750
914	36	227	500

7350 Series Belted Z-Frame Conveyor					
Belt Width		Pulling the Belt		Pushing the Belt	
mm	in	Kg	Lb	Kg	Lb
152	6	45	100	23	50
203	8	45	100	23	50
254	10	45	100	23	50
305	12	45	100	23	50
356	14	45	100	23	50
406	16	45	100	23	50
457	18	45	100	23	50
508	20	45	100	23	50
559	22	45	100	23	50
610	24	45	100	23	50

Maximum Load Capacity (continued)

7350 Series Modular Belt Z-Frame Conveyor			
Belt Width		Pulling the Belt	
mm	in	Kg	Lb
203	8	45	100
254	10	45	100
305	12	45	100
356	14	45	100
406	16	45	100
457	18	45	100
508	20	45	100
559	22	45	100
610	24	45	100

7350 Series Modular Belt Curve Conveyor			
Belt Width		Pulling the Belt	
mm	in	Kg	Lb
152	6	182	400
305	12	227	500
457	18	227	500
610	24	227	500

7350 Series Positive Drive Belt Conveyor			
Belt Width		Pulling the Belt	
mm	in	Kg	Lb
203	8	136	300
254	10	159	350
305	12	182	400
356	14	205	450
406	16	227	500
457	18	227	500
508	20	227	500
559	22	227	500
610	24	227	500
660	26	227	500
711	28	227	500
762	30	227	500
813	32	227	500
864	34	227	500
914	36	227	500

No Load Torque:

No load torque is the amount of torque required to turn an empty conveyor. The torque value varies by conveyor length and configuration. The following charts provide basic values for an average length conveyor. Your specific conveyor may not have a higher value. Please confirm your no load torque and maximum load per application with the Dorner DTools program at www.dornerconveyors.com.

Belted Conveyor No Load Torque		
Belt Width mm (in)	Belted End Drive Nm (in-lbs)	Belted Center Drive Nm (in-lbs)
152 (6)	0.9 (8)	7.9 (70)
203 (8)	1.1 (10)	8.6 (76)
254 (10)	1.5 (13)	9.2 (81)
305 (12)	1.7 (15)	9.9 (88)
356 (14)	2.3 (20)	10.2 (90)
406 (16)	2.3 (20)	10.2 (90)
457 (18)	2.8 (25)	10.5 (93)
508 (20)	3.1 (27)	10.9 (96)
559 (22)	3.1 (27)	11.2 (99)
610 (24)	3.4 (30)	11.9 (105)
660 (26)	3.7 (33)	12.5 (111)
711 (28)	3.7 (33)	12.5 (111)
762 (30)	4 (35)	13.2 (117)
813 (32)	4.3 (38)	13.8 (122)
864 (34)	4.3 (38)	13.8 (122)
914 (36)	4.3 (38)	14.8 (131)

Straight Modular Belt Conveyor:

The no load torque on modular belt straight conveyors is dependent on the conveyor length and width. Use the following formula to determine no load torque. Where:

L = conveyor length (mm)

W = conveyor width (mm)

BW = belt weight (kg) = $(W/1000) * ((L^2)/1000) * 8.7$ kg/square meter

PD = sprocket pitch diameter (mm) = 99 mm

$$\text{No load Torque (Nm)} = \text{BW} * (0.3) * ((\text{PD}/2)/1000) * 9.8$$

Example: 7350 V2 Series Straight Modular Belt, 610 mm wide x 7000 mm long

Belt weight (kg) = $(610/1000) * ((7000^2)/1000) * 8.7 = 74.3$ kg

No load torque (Nm) = $74.3 * 0.3 * ((99/2)/1000) * 9.8 = 10.8$ Nm

No load torque (in-lb) = $(\text{Nm}) * 8.851 = 10.8 * 8.851 = 95.4$ in-lb

Curve Modular Belt Conveyor:

The torque calculations for curve conveyors are complicated and are very dependent on the conveyor save and configuration. Please confirm your no load torque and maximum load per application with the Dorner DTools program at www.dornerconveyors.com.

Belting and Coefficient of Friction

The coefficient of friction is used to determine the load a conveyor can carry. It effects a conveyor in two ways: the friction that exists between the conveyor belt and the bed surface, and if accumulating product, the friction that exists between the conveyor top surface and the product.

Coefficient of Friction, between the bottom of the conveyor belt and bed surface:

Product	Surfaces	Application Condition	Coefficient of Friction
7350 Series Belted	Impregnated polyester fabric to anodized aluminum bed plate	Dry	0.33
7350 Series Modular Belt	Acetal modular belt to UHMW wear strips	Dry	0.30

Coefficient of Friction, between the top surface of conveyor belt and product:

7350 Series Belt

The following table provides the coefficient of friction between steel product and various belt top surfaces. All factors below are assuming dry conditions.

Belt Number	Top Surface Material and Type	Coefficient of Friction
01, 54, 58, 68, 73, 81	Smooth hard urethane	0.40
02, 59, 60, 61, 66, 72, 76, 79	Smooth medium urethane	0.50
03, 19, 55, 69, 75, 77, 78, 80	Glossy soft urethane	>1.0, do not accumulate
05, 06, 50, 53, 63	Impregnated polyester fabric	0.20
08, 18, 64	PVC, Very High friction	>1.0, do not accumulate

7350 Series Modular Belt

The following table provides the coefficient of friction between acetal modular belt and various products. All factors below are assuming dry conditions.

Product Being Accumulated	Typical Coefficient of Friction
Steel	0.25
Glass	0.20
Aluminum	0.25
Plastic	0.25
Wood	0.30
Paper and Cardboard	0.30

Calculating Conveyor Load Capacity

There are several factor that effect the overall conveyor load of AquaGard 7350 Series Conveyor. These include:

- Conveyor size and configuration
- Conveyor speed
- Application temperature
- Product accumulation
- Number of starts and stops per hour

Located online at www.dornerconveyors.com is the Dorner conveyor configuration tool, DTools. This tool allows you to configure your conveyor layout and determine the maximum load capacity for the conveyor. It is suggested that this program be used to calculate the conveyor load as the calculation is quite complicated. This configuration program however does not take into account temperature, dirty conditions, and conveyor starts and stops. If these conditions are part of your application please use the load reducing factors as shown below.

$$\text{Maximum Load} = (\text{Load from DTools})(\text{Temperature Factor})(\text{Start/Stop Factor})$$

Temperature Factor		
Ambient temperature can negatively affect the capacity of the conveyor.		
Temperature F	Temperature C	Temperature Factor
-4	-20	1.0
32	0	1.0
68	20	1.0
104	40	0.9
140	60	0.8

Start / Stop Factor	
Frequent Start / Stops of the conveyor can negatively affect the capacity of the conveyor. All start / stop applications must use a soft start mechanism such as a Frequency Inverter with a 1 second acceleration cycle.	
Application Condition	Start / Stop Factor
Continuous Run or 1 start/stop per hour	1.0
Maximum 10 starts/stop per hour	0.83
Maximum 30 starts/stop per hour	0.70
Greater than 30 starts/stop per hour	0.62

Calculating Conveyor Belt Speed:

AquaGard 7350 Series Conveyors:

To calculate the conveyor belt speed you need to know the following factors:

DR = Drive roller diameter or drive sprocket pitch diameter (mm)

= 89 mm (3.5 in) for end and center drive belted conveyors

= 99 mm (3.9 in) for end drive modular belt conveyors

= 99 mm (3.9 in) for end positive drive belt conveyors

TD = Number of teeth of pulley located at drive roller (if equipped)

TG = Number of teeth of pulley located at gearmotor (if equipped)

RPM = Revolutions per minute of gearmotor

$$\text{Belt Speed (m/min)} = \text{RPM} \cdot (\text{TD}/\text{TG}) \cdot (\text{DR}/1000) \cdot 3.14$$

Example:

AquaGard 7350 Series Belted End Drive, bottom mount with a 36 tooth pulley located at the drive roller and a 30 tooth pulley located on the gearmotor. The gearmotor is a 10:1 ratio with 173 rpm output.

$$\text{Belt Speed (m/min)} = (173) \cdot (36/30) \cdot (89/1000) \cdot 3.14$$

$$\text{Belt speed (m/min)} = 58 \text{ m/min}$$

$$\text{Belt speed (ft/min)} = 58 \text{ m/min} \cdot (3.28) = 190 \text{ ft/min}$$

$$\text{No load torque (Nm)} = 74.3 \cdot 0.3 \cdot ((99/2)/1000) = 1.1 \text{ Nm}$$

$$\text{No load torque (in-lb)} = (\text{Nm}) \cdot 8.851 = 1.1 \cdot 8.851 = 9.77 \text{ in-lb}$$

Dorner AquaGard Conveyors are Best for:

- Baking
- Secondary Packaging
- Confectionary
- Packaged Foods
- Snack Foods
- Elevation Changes
- Pet Foods
- Tight Transfers
- And More!

7200 & 7300 Series Specifications*

- Belted and Cleated Belt Models
- Loads up to 27 kg (60 lbs)
- Widths: 44 mm (1.75 in) to 457 mm (18 in)
- Lengths: 610 mm (2 ft) to 8,486 mm (18 ft)
- 11 gauge Stainless Steel roll formed frame
- 7300 features a high pressure bearing option
- Available in straights only

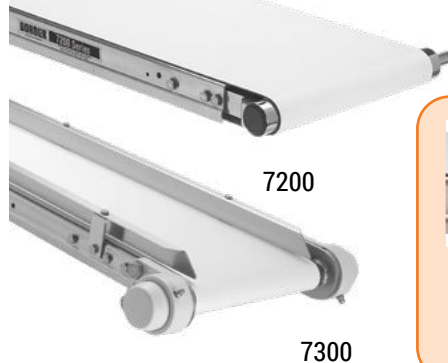



7200 Rated for Wipe Down and Wet Environments



7300 Rated for Wash Down with Chlorinated Cleaners

7350 Series Specifications

- Belted, Cleated Belt, Modular Belt, Modular Cleated Belt Models and Positive Drive Options
- Loads up to 341 kg (750 lbs)
- Widths: 152 mm (6 in) to 914 mm (36 in)
- Lengths: 914 mm (3 ft) to 25,000 mm (82 ft)
- FDA approved belting and plastic components
- 304 Stainless Steel frame
- Available in straights, curves or Z-Frame configurations



Straights



Curves (Modular Belt Only)

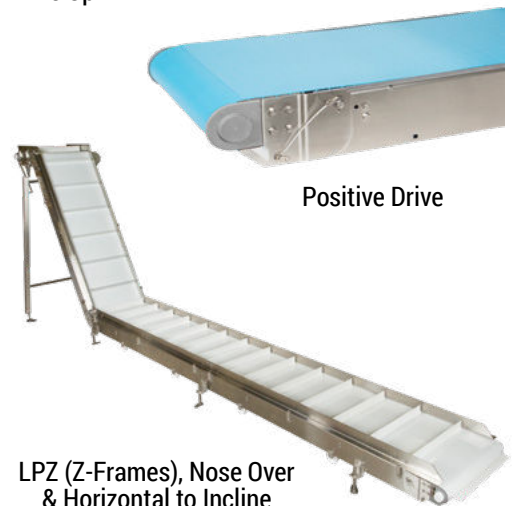

LPZ (Z-Frames), Nose Over & Horizontal to Incline

Positive Drive

Options



Nose Bar Transfers



Powered Transfers



Variety of Guiding Options

Other options available including Roller Transfers, Chutes, Drip Pans, Formed Angle Stands, Hoppers and more.

*Please refer to the AquaGard 7200 & 7300 Series manual for product information.



Industrial



Flexible Chain



Pallet Systems



Sanitary Stainless Steel

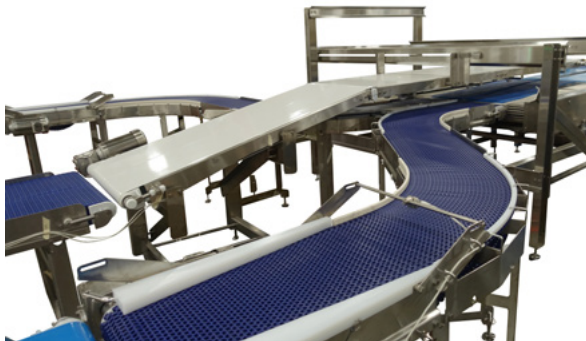

Engineered Solutions Group

Custom engineered solutions for almost any application.



CAD Configurator Tool

Industry leading tool! Configure your own custom conveyor in minutes.

TRANSFORMING CONVEYOR AUTOMATION

Contact Dorner

United States
+1-262-367-7600

Canada
+1-289-208-7306

Mexico
+52.33.30037400

Germany
+49 (0) 2461/93767-0

France
+33 (0)1 84 73 24 27

Malaysia
+604-626-2948



By Columbus McKinnon

DORNERCONVEYORS.COM



CONVEYANCE SOLUTIONS



MAGNETEK

montratec

© Dorner Mfg. Corp. 2024. All Rights Reserved.

851-895 0124